

6-3. BLOCK DIAGRAM – AMP/POWER SUPPLY Section –

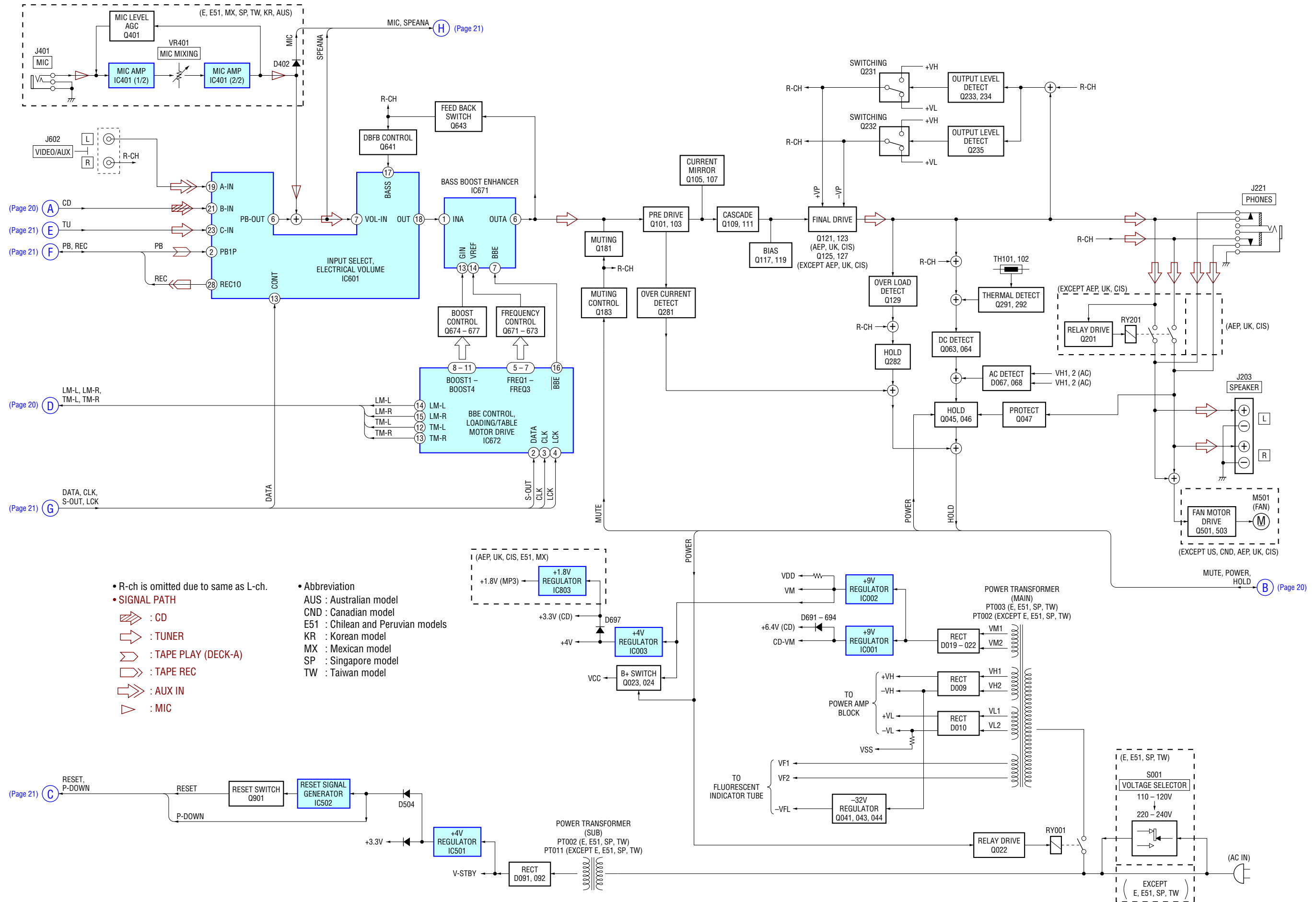

• R-ch is omitted due to same as L-ch.

• SIGNAL PATH

- ➡ : CD
- ➡ : TUNER
- ➡ : TAPE PLAY (DECK-A)
- ➡ : TAPE REC
- ➡ : AUX IN
- ➡ : MIC

• Abbreviation

- AUS : Australian model
- CND : Canadian model
- E51 : Chilean and Peruvian models
- KR : Korean model
- MX : Mexican model
- SP : Singapore model
- TW : Taiwan model