

SERVICE MANUAL

15" LCD Monitor L1506



THESE DOCUMENTS ARE FOR REPAIR SERVICE INFORMATION ONLY. EVERY REASONABLE EFFORT HAS BEEN MADE TO ENSURE THE ACCURACY OF THIS MANUAL; WE CANNOT GUARANTEE THE ACCURACY OF THIS INFORMATION AFTER THE DATE OF PUBLICATION AND DISCLAIMS RELIABILITY FOR CHANGES, ERRORS OR OMISSIONS.

Table of Contents

Table of Contents -----	02
Revision List-----	04
1.Product Feature-----	05
2.LCD Monitor Description -----	05
3.Operation Instructions -----	06
3.1 General Instructions -----	06
3.2 Control Button -----	07
3.3 Adjusting The Picture -----	07
4. Input/Output Specification -----	09
4.1 Input Signal Connector -----	09
4.2 Factory Preset Display Modes -----	10
4.3 Power Supply Requirements -----	10
5.Panel Specification -----	11
5.1 General Feature -----	11
5.2 Optical Characteristics -----	12
6. Block Diagram -----	13
6.1 Monitor Exploded View-----	13
6.2 Software Flow Chart-----	14
6.3 Electrical Block Diagram -----	15
6.3.1 Scalar Board -----	15
6.3.2 Inverter/Power Board -----	16

7. Schematic -----	18
7.1 Main Board -----	18
7.2 Power Board -----	24
8. PCB Layout -----	26
8.1 Main Board -----	26
8.2 Inverter/Power Board -----	27
8.3 Key board -----	28
9. Maintainability -----	29
9.1 Equipments and Tools Requirements -----	29
9.2 Trouble Shooting -----	30
9.2.1 Main Board -----	30
9.2.2 Power/Inverter Board -----	33
9.2.3 Key Pad Board -----	35
10. White-Balance, Luminance Adjustment -----	36
11. Check List after replacing LCD Main board -----	37
12. EDID Content -----	41
13. BOM List -----	42 ~ 66

	Panel	CLAA150XP02
	Size	38.1cm(15.0")
	Pixel pitch	0.297mm(H)x 0.297mm(V)
	Viewable angle	130° (H) 100° (V)
	Response time (typ.)	<16 ms
	Brightness(Min)	250
	Contrast	400:1
	Video	Analog /Digital
Input	Sync. Type	H/V TTL
	H-Frequency	30kHz – 63kHz
	V-Frequency	50-76Hz
Display Colors	Over 16 million Colors	
Dot Clock	80MHz	
Max. Resolution	1024 x768	
Plug & Play	VESA DDC2B™	
Power Consumption	ON Mode	<23W
	OFF Mode	<1W
Screen Size	Horizontal : 306mm Vertical : 230 mm	
Environmental Considerations	Operating Temp: 5°C to 35°C Storage Temp.: -20°C to 60°C Operating Humidity : 20% to 80%	
MAIN DIMENSIONS	Packaged(W*H*D)	395mm*395mm*155mm
	Unpackaged(W*H*D)	340mm*355mm*203mm
Weight (N. W.)	Packaged	≤4.6Kg Unit
	Unpackaged	≤3.5Kg Unit

2. LCD Monitor Description

The LCD Monitor will contain main board, power board, key board and which house the flat panel control logic, brightness control logic and DDC.

The power board will provide AC to DC Inverter voltage to drive the backlight of panel and the main board chips each voltage.

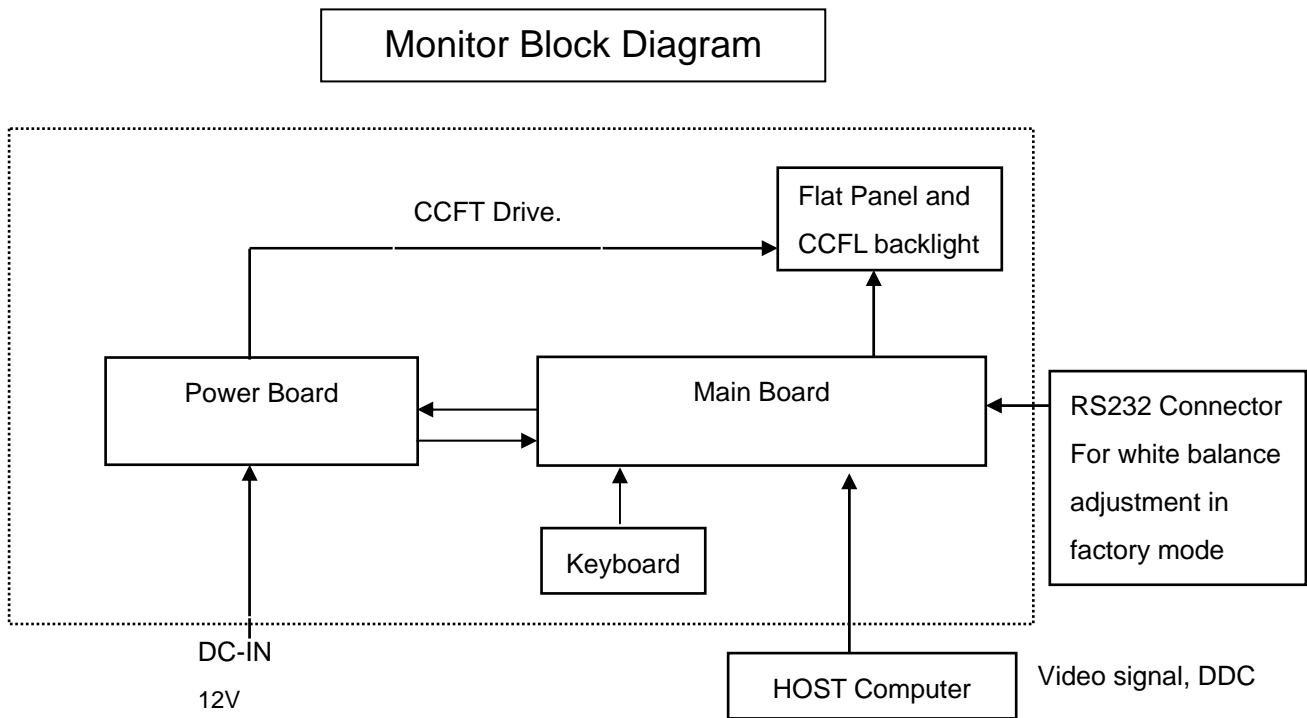

3. Operation Instructions

3.1 General Instructions

Press the power button to turn the monitor on or off. The other control buttons are located at front of the panel. By changing these settings, the picture can be adjusted to your personal performance.

- The power cord should be connected and insert to adaptor.
- Connect the video cable from the monitor to the computer VGA card.
- Press the power button to turn on the monitor, the power indicator will light up to Green.

3.2 Control Buttons

- **Power Button:**

When pressed, the monitor enters the off mode, and the LED turns blank. Press again to restore normal status.

- Left / Right Button:

When the OSD show on screen, Left/Right Button are used to control the monitor functions. Press to switch functions or adjust settings. And if the OSD off, Left buttons is used to automatically set the H Position, V Position, Clock and Phase.

- Power Indicator:

- Green — Power On mode.
- Orange — Power Saving mode.
- Blank —Power Off Mode.

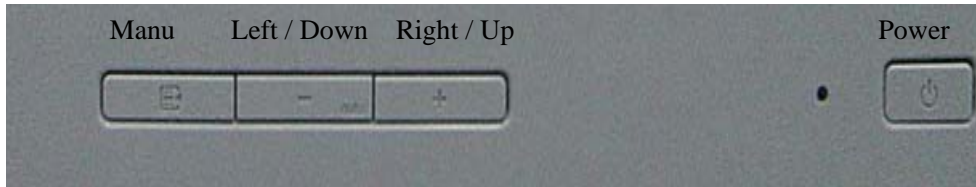

A. Menu button / Exit









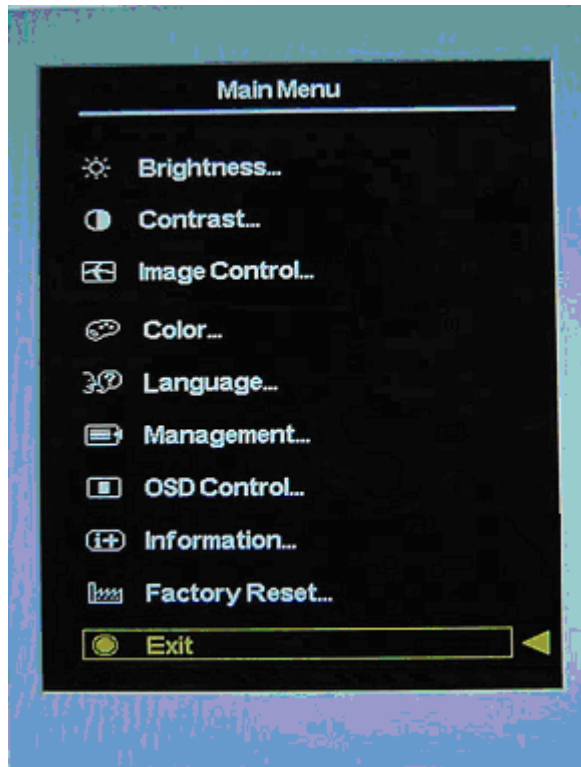

B. Left/(Down) button / Auto button

C. Up button

D. Power button

3.3 Adjust the Picture



1.		Brightness	Adjust the brightness.
2.		Contrast	Adjust the contrast
3.		Image Control	Adjust the: <ul style="list-style-type: none"> ● Auto Adjustment: Adjusts the main settings and produces a stable, centered image. ● H-Position: horizontal position of the screen image. ● V-Position: vertical position of the screen image. ● Clock: frequency of the pixel clock to minimize vertical bar. ● Phase: phase value to minimize horizontal jitters.
4.		Color	<ul style="list-style-type: none"> ● 9300K: recall 9300K color ● 6500K: recall 6500K color ● SRGB: recall SRGB color ● Custom Color: adjusts the color tint of white, and the red, green, and blue (RGB) mix for colors.
5.		Language	Shows the language of the OSD window.
6.		Management	<ul style="list-style-type: none"> ● Power Saver: enable/disable power saving ● Power On Recall: enable/disable power recall ● Mode Display: enable/disable mode display ● Sleep Timer: set sleep timer ● Basic Menu: set to basic menu
7.		OSD Control	OSD (on Screen Display) settings: adjusts the H/V position, timeout, On Screen Display window.
8.		Information	Current setting, recommended setting, serial number, total hours, backlight hours, Exit.
9.		Factory Reset	Resets the display to original factory settings for color, brightness, phase, and clock.
10.		Exit	Exit the current OSD window.

4. Input/Output Specification

4.1 Input Signal Connector

PIN	MNEMONIC	SIGNAL	PIN	MNEMONIC	SIGNAL
1	RV	Red Video	9	+3.3/+5 V	+3.3/+5 V (from PC)
2	GV	Green Video	10	SG	Sync Ground
3	BV	Blue Video	11	NC	None (Reserved for Factory Use)
4	NC	No Connect	12	SDA	DDC Data
5	GND	Ground (DDC Return)&Cable Detect	13	HS	Horizontal Sync
6	RG	Red GND	14	VS	Vertical Sync
7	GG	Green GND	15	SCL	DDC Clock
8	BG	Blue GND			

VGA connector layout

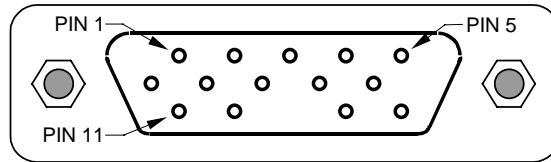

4.2 Factory Preset Display Modes

Preset	Pixel Format	Horz Freq (KHz)	Horz Polarity	Vert Freq (Hz)	Vert Polarity	Pixel Clk (MHz)	Source
1	640 x 480	31.469	-	59.940	-	25.175	VGA
2	640 x 480	37.861	-	72.809	-	31.500	VESA
3	640 x 480	37.500	-	75.000	-	31.500	VESA
4	720 x 400	31.469	-	70.087	+	28.322	VGA
5	800 x 600	37.879	+	60.317	+	40.000	VESA
6	800 x 600	48.077	+	72.188	+	50.000	VESA
7	800 x 600	46.875	+	75.000	+	49.500	VESA
8	832 x 624	49.726	±	74.551	±	57.284	MAC
9	1024 x 768	48.363	-	60.004	-	65.000	VESA
10	1024 x 768	56.476	-	70.069	-	75.000	VESA
11	1024 x 768	60.023	+	75.029	+	78.750	VESA
12	1152 x 870	68.68	-	75.06	-	100.000	Mac
13	1152 x 900	71.71	-	76.05	-	105.561	Sun
14	1280 x 1024	63.98	+	60.02	+	108.000	VESA
15	1280 x 1024	79.97	+	75.02	+	135.000	VESA

4.3 Power Supply Requirements

PARAMETER	RANGE
AC Input Voltage	90 to 265V
AC Input Frequency	47 to 63 Hz
Inrush Current	50A MAX AT 220VAC and 30A AT 120VAC
Leakage Current	5 mA MAX at 120VAC
Power consumption	≤23W

5. PANEL SPECIFICATION

5.1 General Feature

ITEM	SPECIFICATION
Display Area(mm)	304.1 (H) × 228.1 (V) (15.0 inch diagonal)
Number of Pixels	1024(H) × 768(V)
Pixel Pitch(mm)	0.297(H) × 0.297(V)
Color Pixel Arrangement	RGB vertical strip
Display Mode	Normally White, TN
Number of Colors	262144
Color Gamun	65%
Brightness(cd/m ²)	250(cd/m ²) @8.0mA
Response Time	16ms
Viewing Angle	(-70~70)(H), (-65~60)(V)(Typ.)
Wide Viewing Angle Technology	Super wide view film
Surface Treatment	Hard coating:3H ; Anti-glare
Electrical Interface	RSDS
Total Module Power(W)	12.5 W
Module Size(mm)	326.5 (W) × 253.5 (H) × 11.0 (D) (Typ.)
Module Weight(g)	1060(Typ.)
Backlight Unit	2 CCFLs of edge light(Top/Bottom)

5.2 Optical Characteristics

ITEM	SYMBOL	CONDITION	MIN.	TYP.	MAX.	UNIT	
Contrast Ratio	•••	$\theta = \phi = 0^\circ$	450	500	550	-	
Luminance	Center	•••	$\theta = \phi = 0^\circ$	200	250	--	cd/m ²
	Average	•••	$\theta = \phi = 0^\circ$	180	(225)	--	
	Uniformity	Δ •••	$\theta = \phi = 0^\circ$	75	80	--	%
Response Time	tr	$\theta = \phi = 0^\circ$	--	5	--	ms	
	tf	$\theta = \phi = 0^\circ$	--	11	--	ms	
Viewing Angle	Horizontal	ϕ	CR• 40	--	-70~70	--	••
	Vertical	θ		--	-65~60	--	••
Color Coordinates	Red	x	$\theta = \phi = 0^\circ$	0.616	0.646	0.676	-
		y		0.303	0.333	0.363	
	Green	x		0.271	0.301	0.331	
		y		0.555	0.585	0.615	
	Blue	x		0.114	0.144	0.174	
		y		0.049	0.079	0.109	
	White	x		0.283	0.313	0.343	
		y		0.299	0.329	0.359	
Color Temperature				6500		K	

6.2 Software Flow Chart

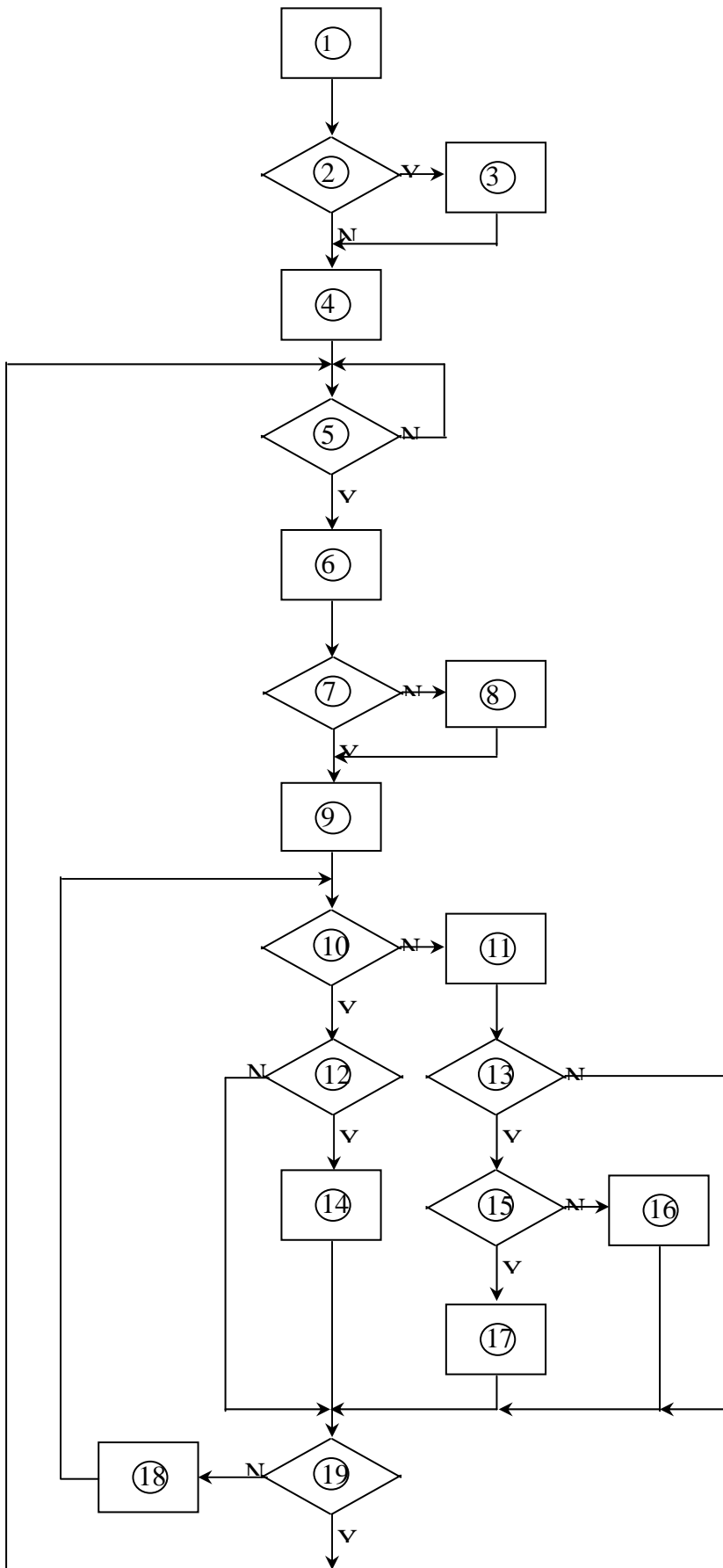

- 1) MCU initialize.
- 2) Is the eeprom blank?
- 3) Program the eeprom by default values.
- 4) Get the PWM value of brightness from eeprom. Check the pin PANEL1 and PANEL2 to tell which panel to get with it.
- 5) Is the power key pressed?
- 6) Clear all global flags.
- 7) Are the AUTO and SELECT keys pressed?
- 8) Enter factory mode.
- 9) Saving the power key status into eeprom. Turn on the LED and set it to green color. Scalar initializes.
- 10) In standby mode?
- 11) Update the lifetime of back light.
- 12) Check the analog and digital port, are there any signals coming?
- 13) Does the scalar send out a interrupt request?
- 14) Wake up the scalar.
- 15) Are there any signals coming from analog or digital port?
- 16) Display " No Input Signal " message. And go into standby mode after the message disappear.
- 17) Program the scalar to be able to show the coming mode.
- 18) Process the OSD display.
- 19) Read the keyboard. Is the power key pressed?

6.3 Electrical Block Diagram

6.3.1 Scalar Board Block Diagram

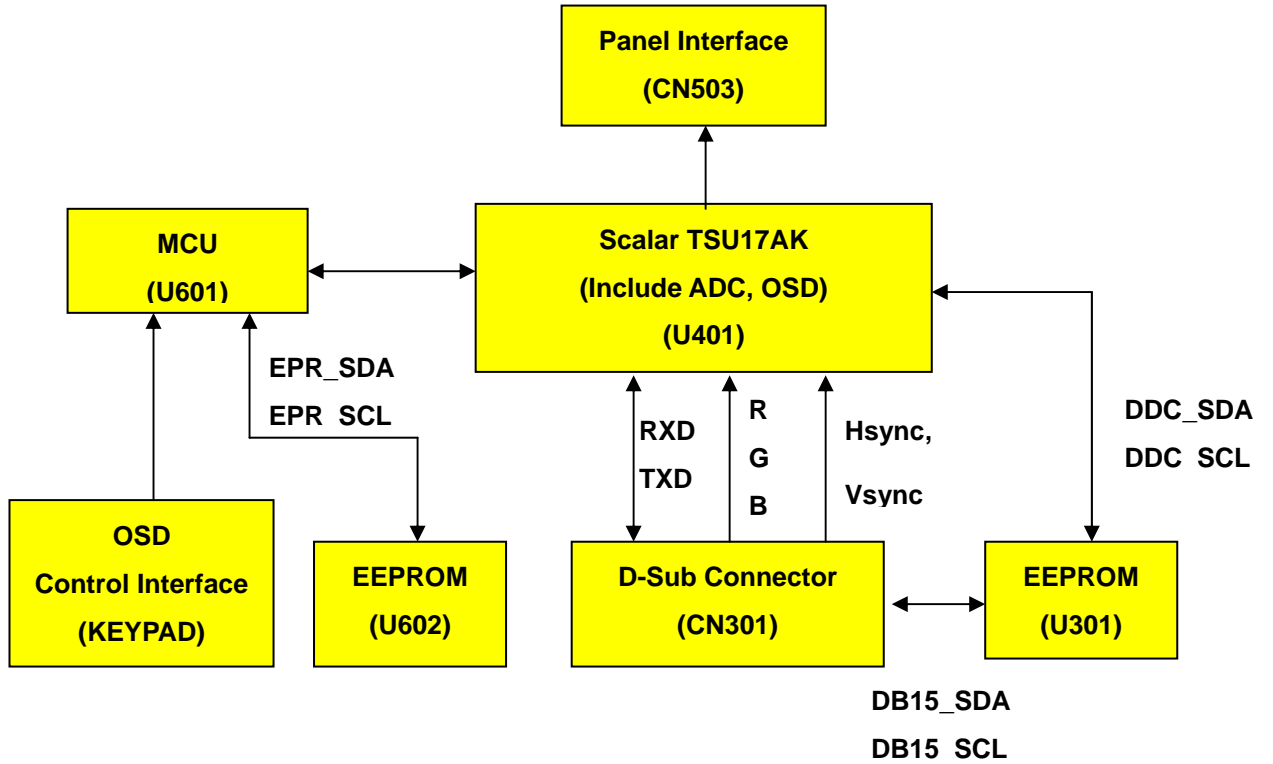

6.3.2 Inverter / Power Board Block Diagram

Inverter Block Diagram

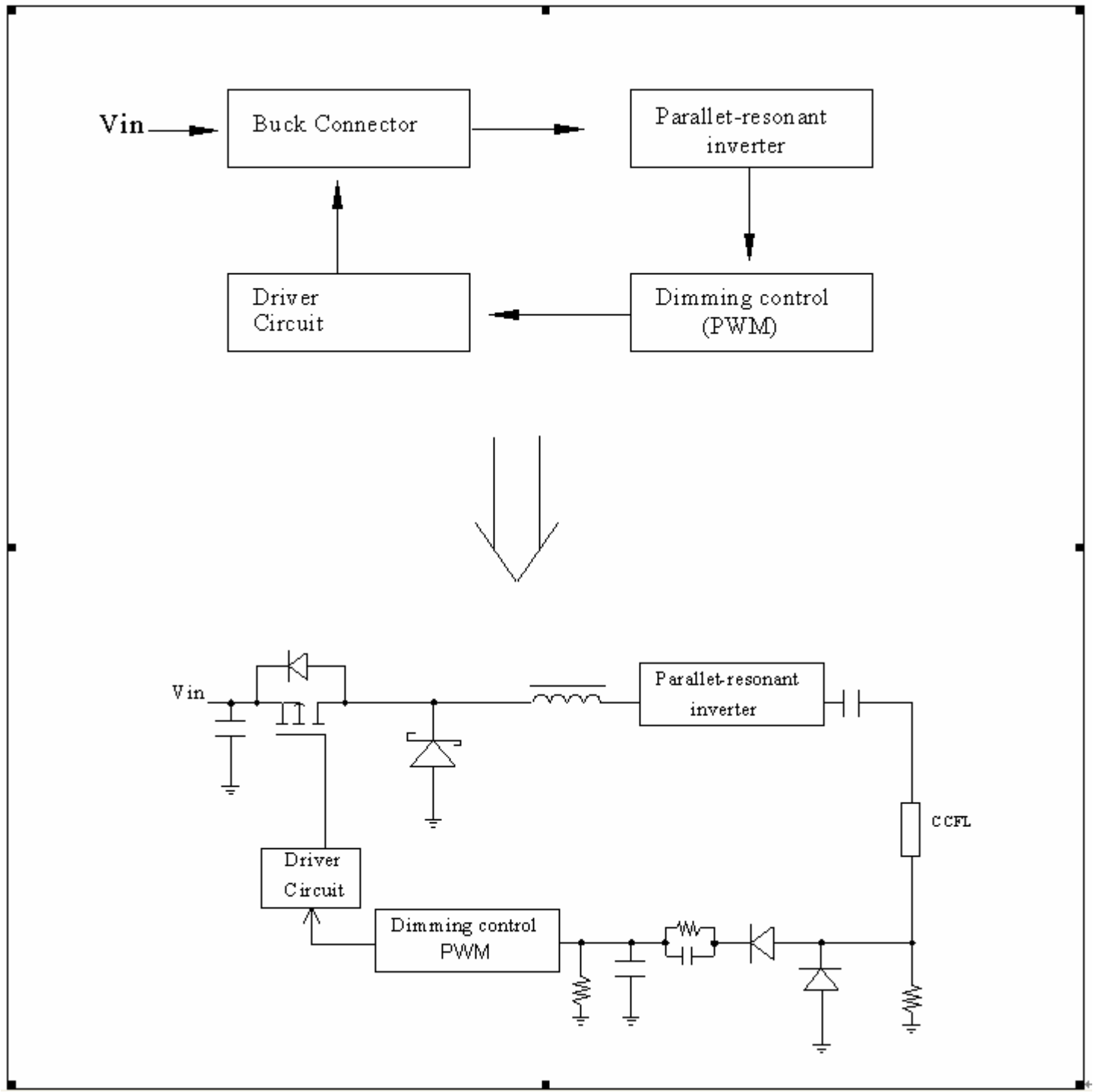

Power Block Diagram

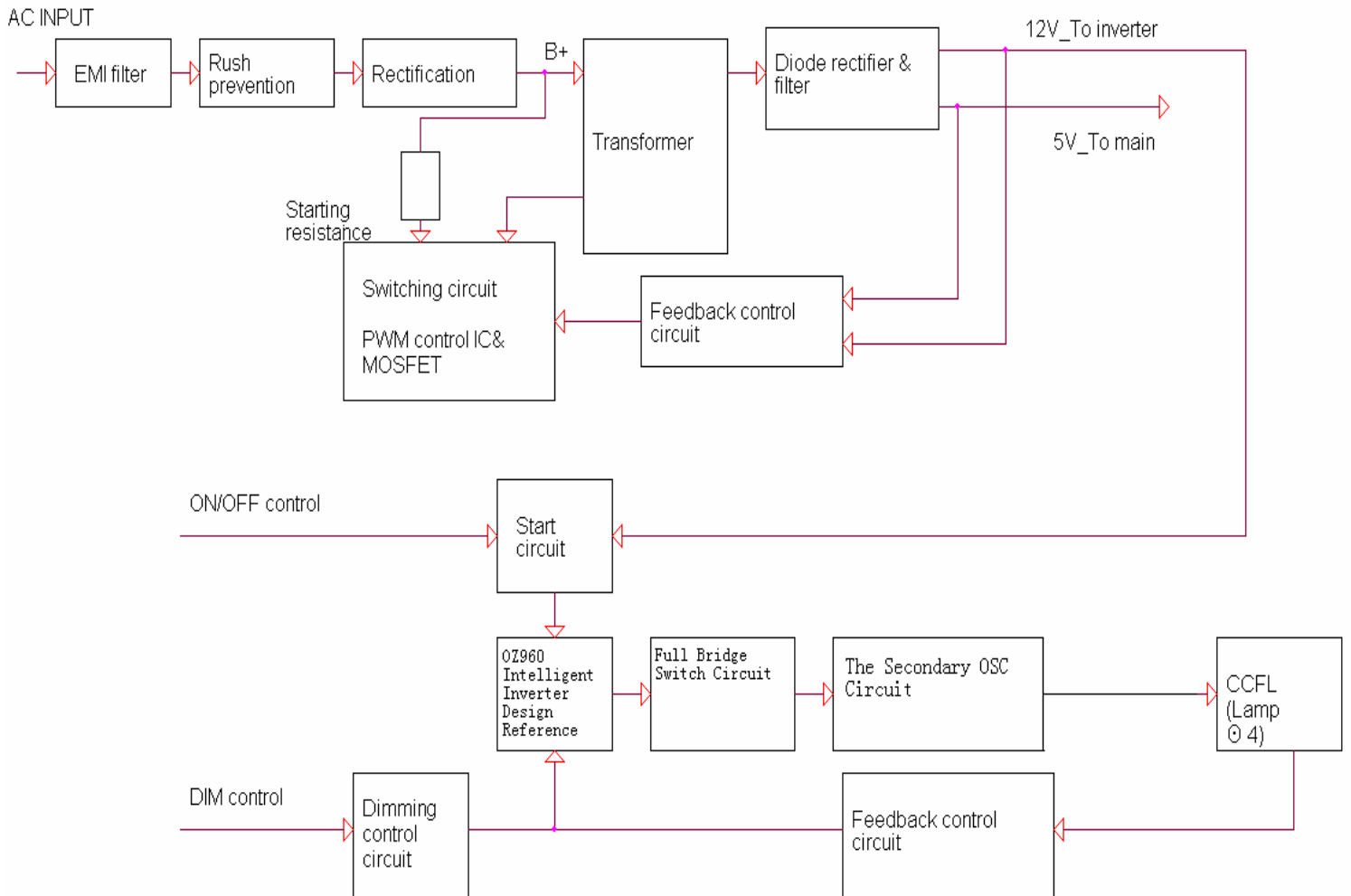

7. Schematic

7.1 Main Board (715G1533-D-MS)

SCHEMATIC FOR HPQ2005 L1506/1706

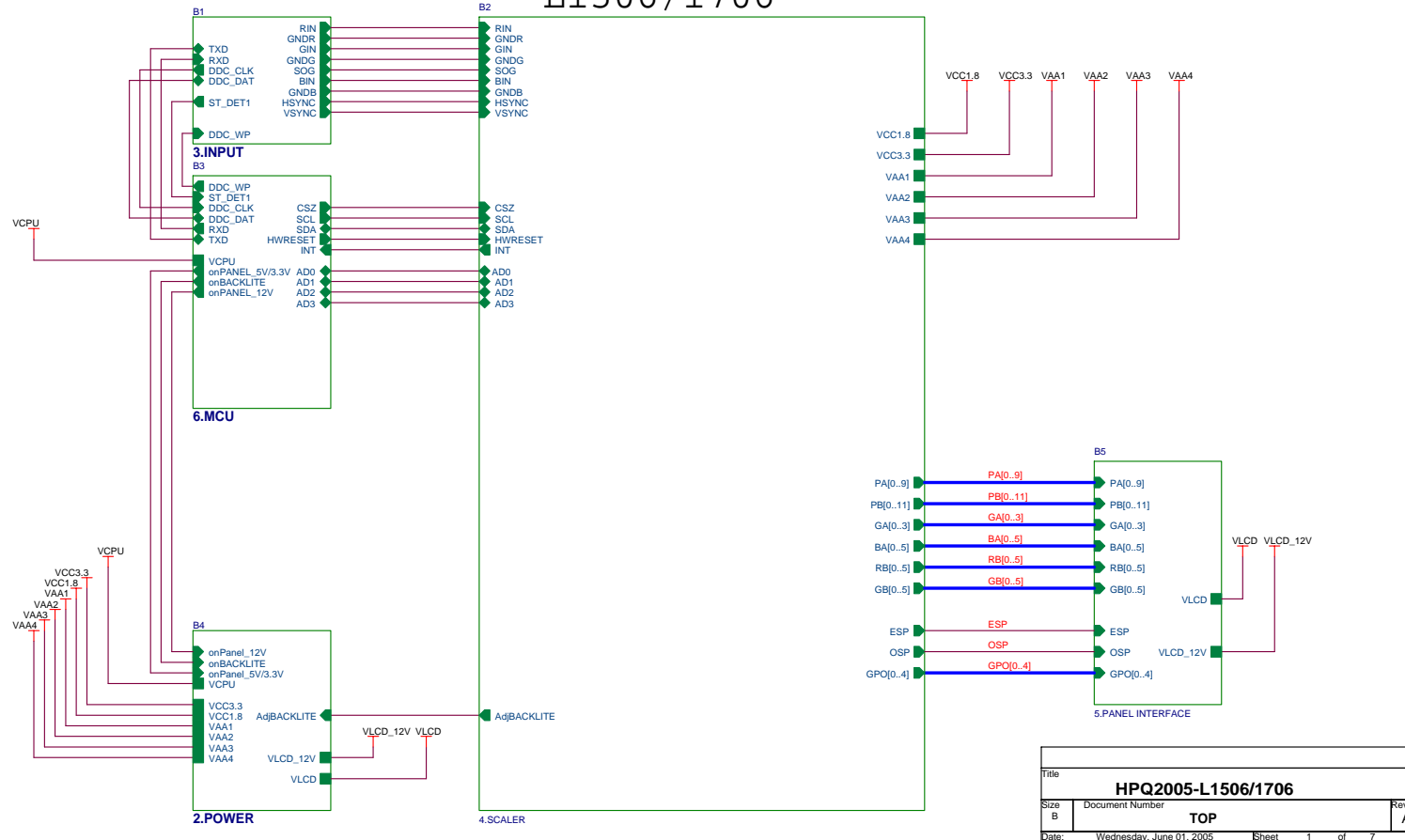

Title		HPQ2005-L1506/1706	
Size	Document Number	Rev	
B	TOP	A	
Date:	Wednesday, June 01, 2005	Sheet	1 of 7

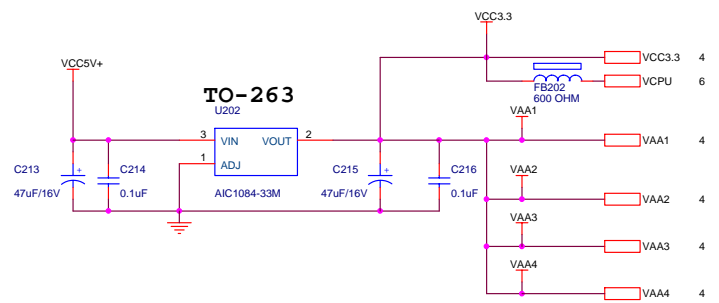
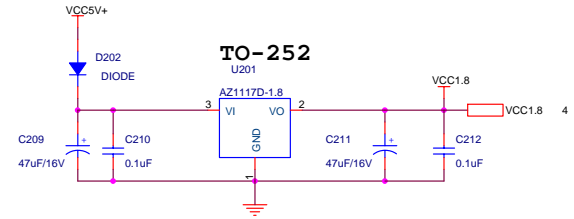
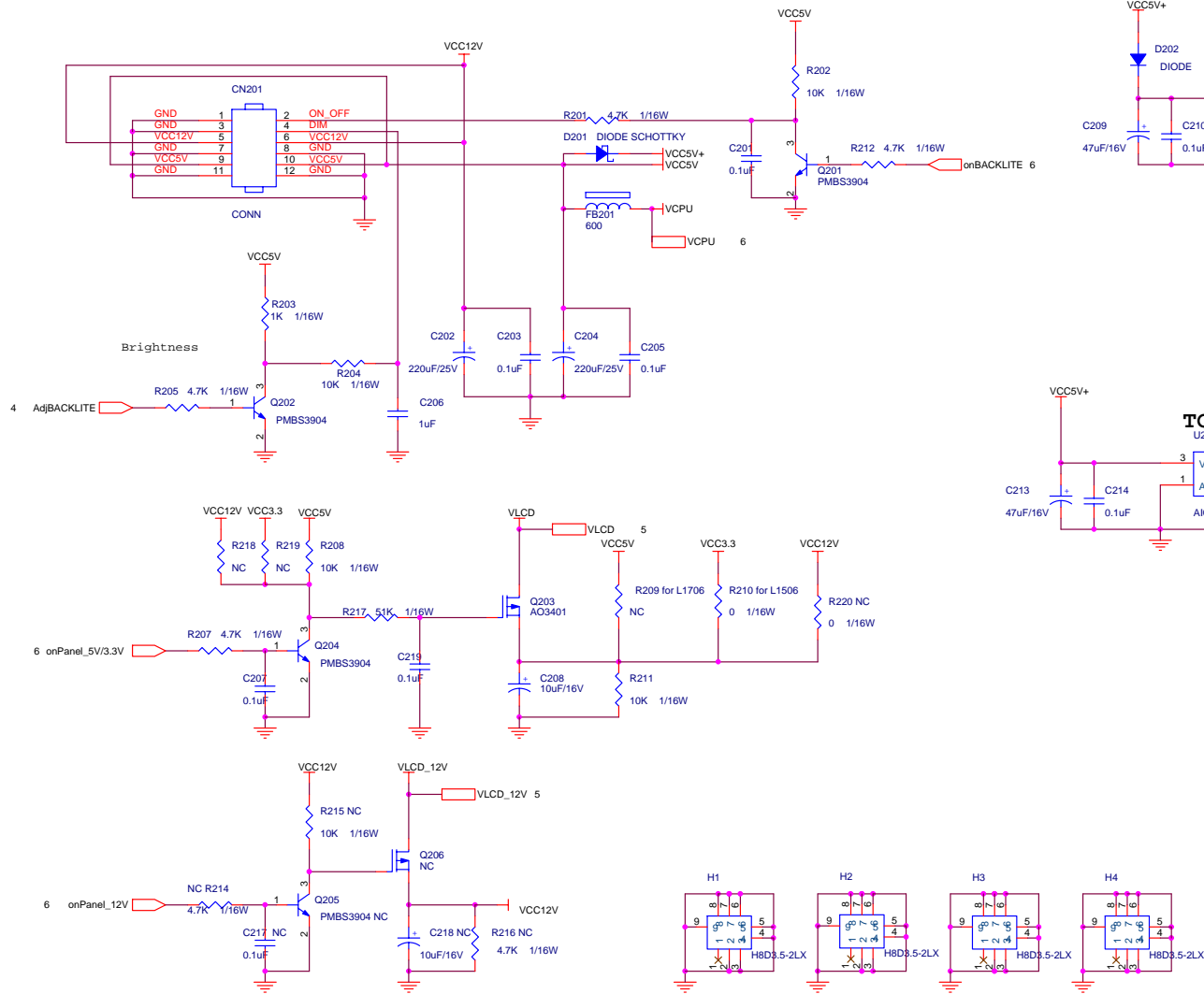

Title		
HPQ2005-L1506/1706		
Size	Document Number	Rev
B	POWER	A
Date:	Wednesday, June 01, 2005	Sheet 2 of 7

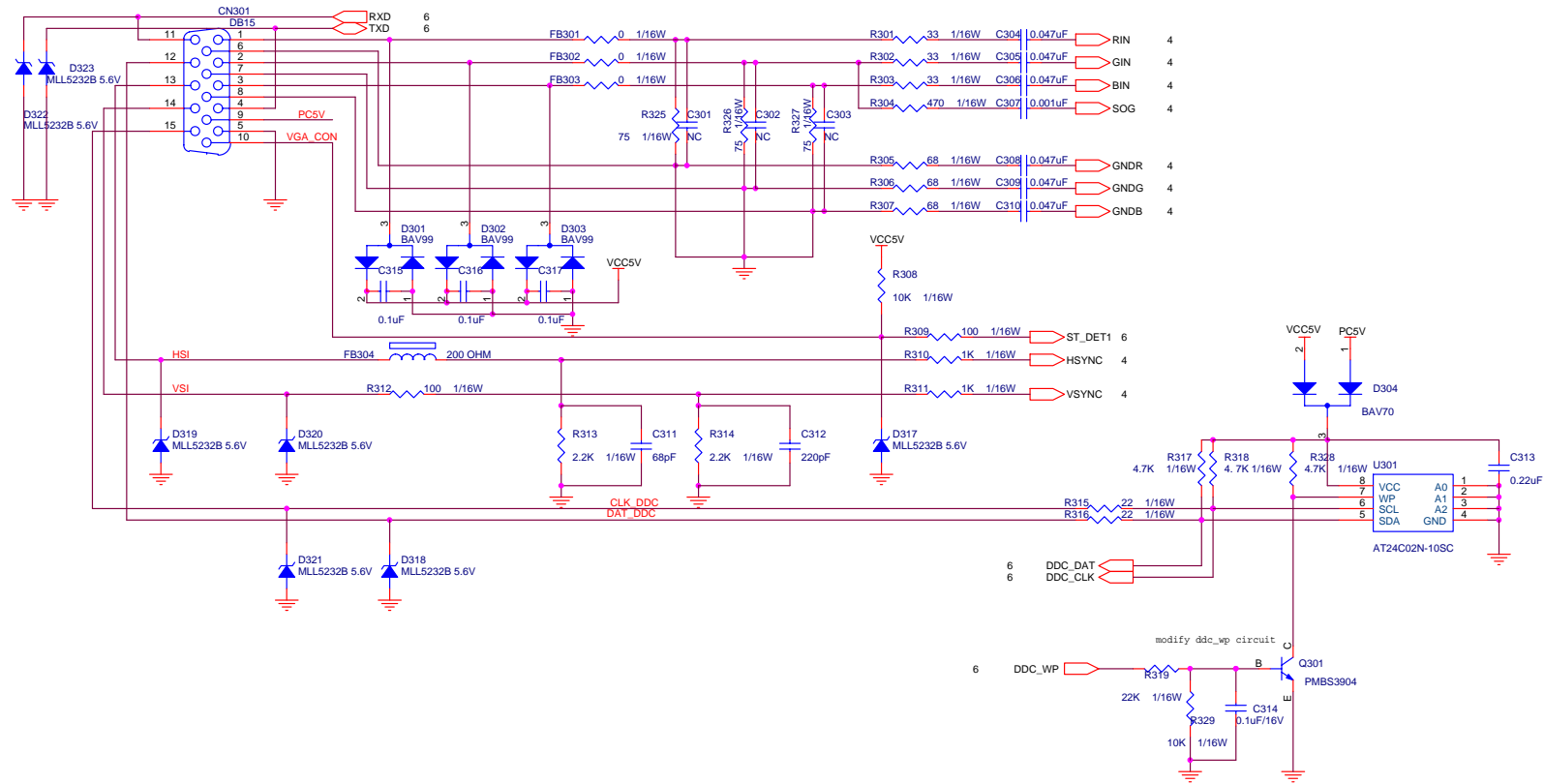

Title			
HPQ2005-L1506/1706			
Size	Document Number	INPUT	Rev
B			A
Date:	Wednesday, June 01, 2005	Sheet	3 of 7

	R401	R402
Direct Bus	NC	4.7K
3-WIRE	4.7K	NC

6
6
6

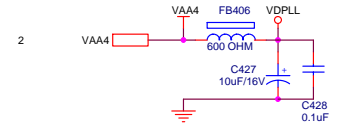
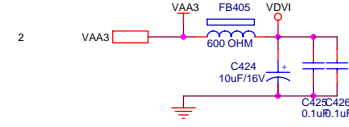
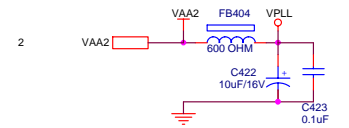
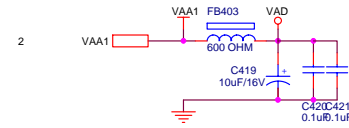
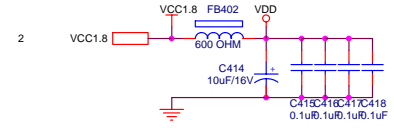
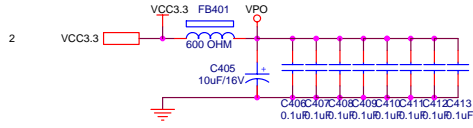
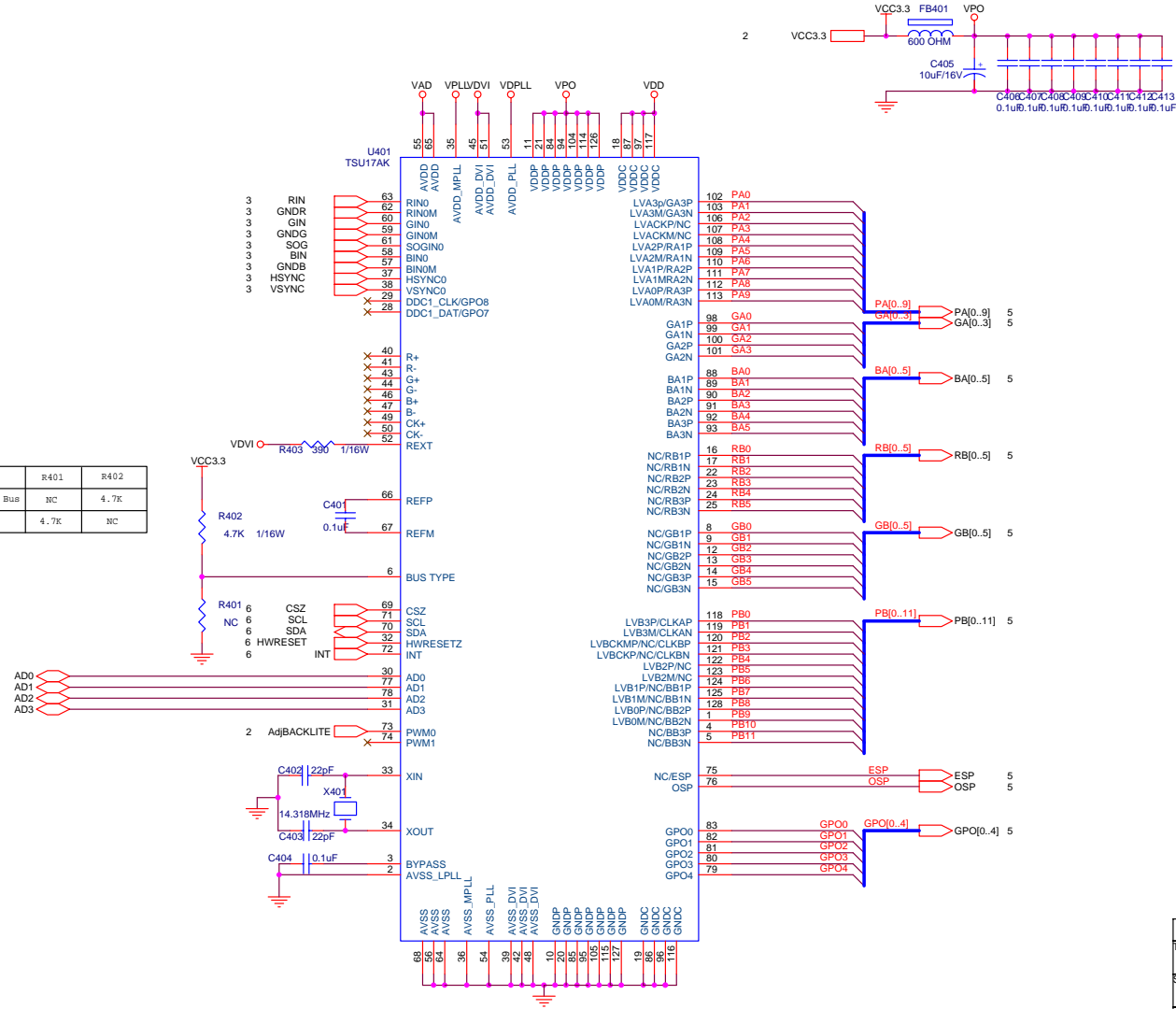

Title		
HPQ2005-L1506/1706		
Size	Document Number	Rev
B	SCALER	A
Date:	Wednesday, June 01, 2005	Sheet 4 of 7

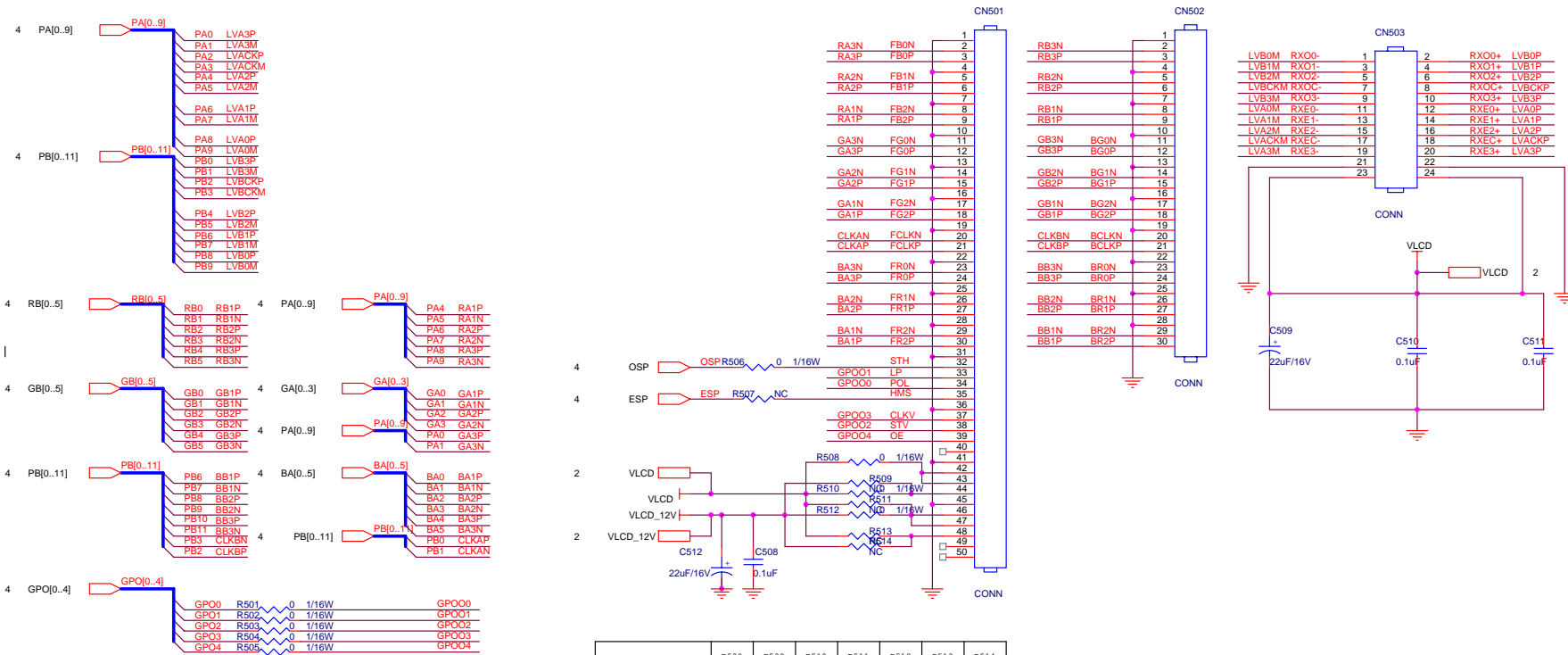

	R508	R509	R510	R511	R512	R513	R514
MU 17	NC	NC	5V	5V	NC	5V	NC
DBI 17	3.3V	12V	OR	OR	12V	OR	12V
CPT 17	OR	OR	NC	NC	OR	NC	OR
INNOLUX 15	3.3V	OR	NC	NC	NC	NC	NC
HannStar 15	3.3V	OR	NC	NC	12V	NC	NC
CPT 15	OR	NC	OR	OR	OR	NC	NC
LG 15	3.3V	OR	NC	NC	NC	NC	NC

Title		
HPQ2005-L1506/1706		
Size B	Document Number	Rev
	PANEL INTERFACE	A
Date:	Wednesday, June 01, 2005	Sheet 5 of 7

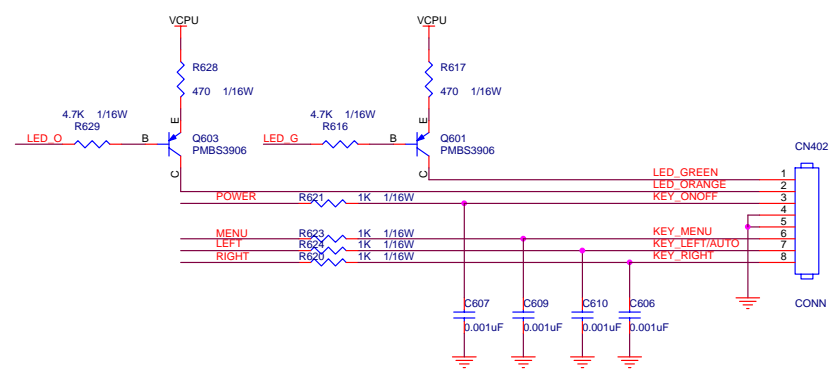
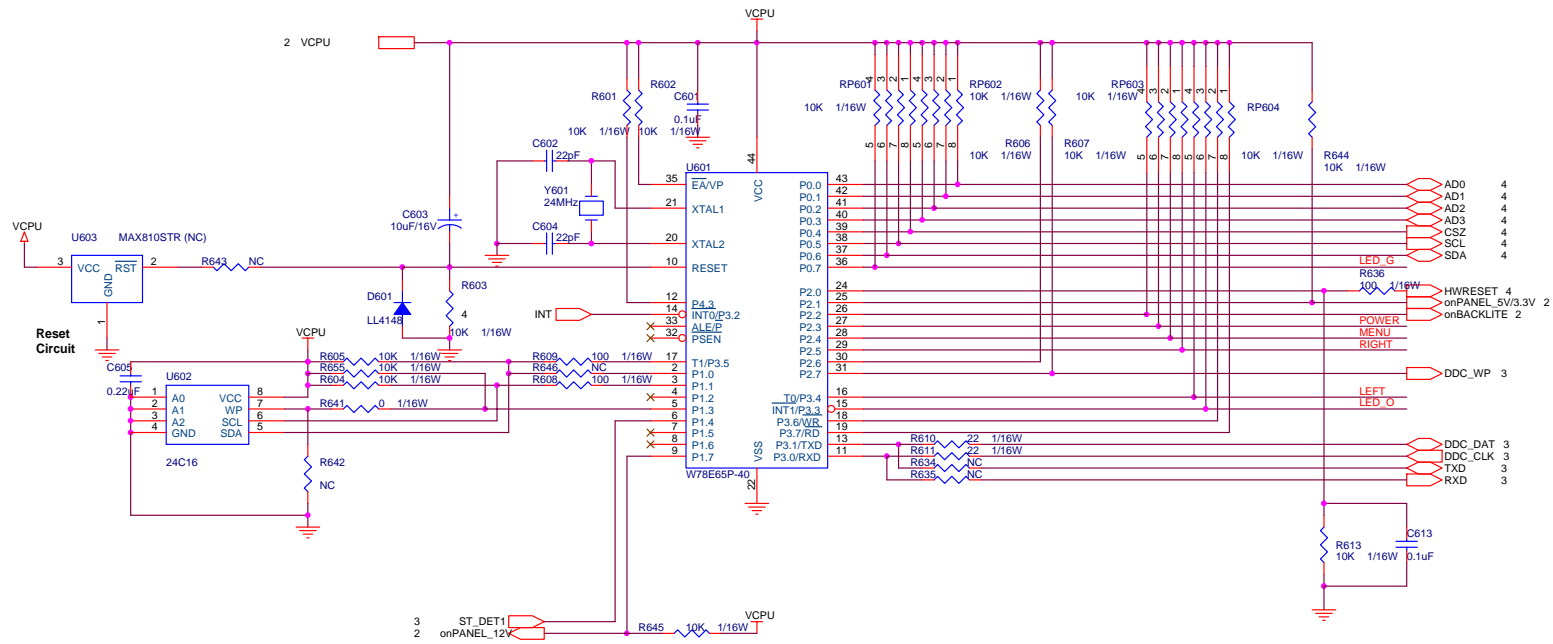

Title		
HPQ2005-L1506/1706		
Size	Document Number	Rev
B	MPU	A
Date:	Wednesday, June 01, 2005	Sheet 6 of 7

7.2 Power Board (include inverter and power) 715G508-1

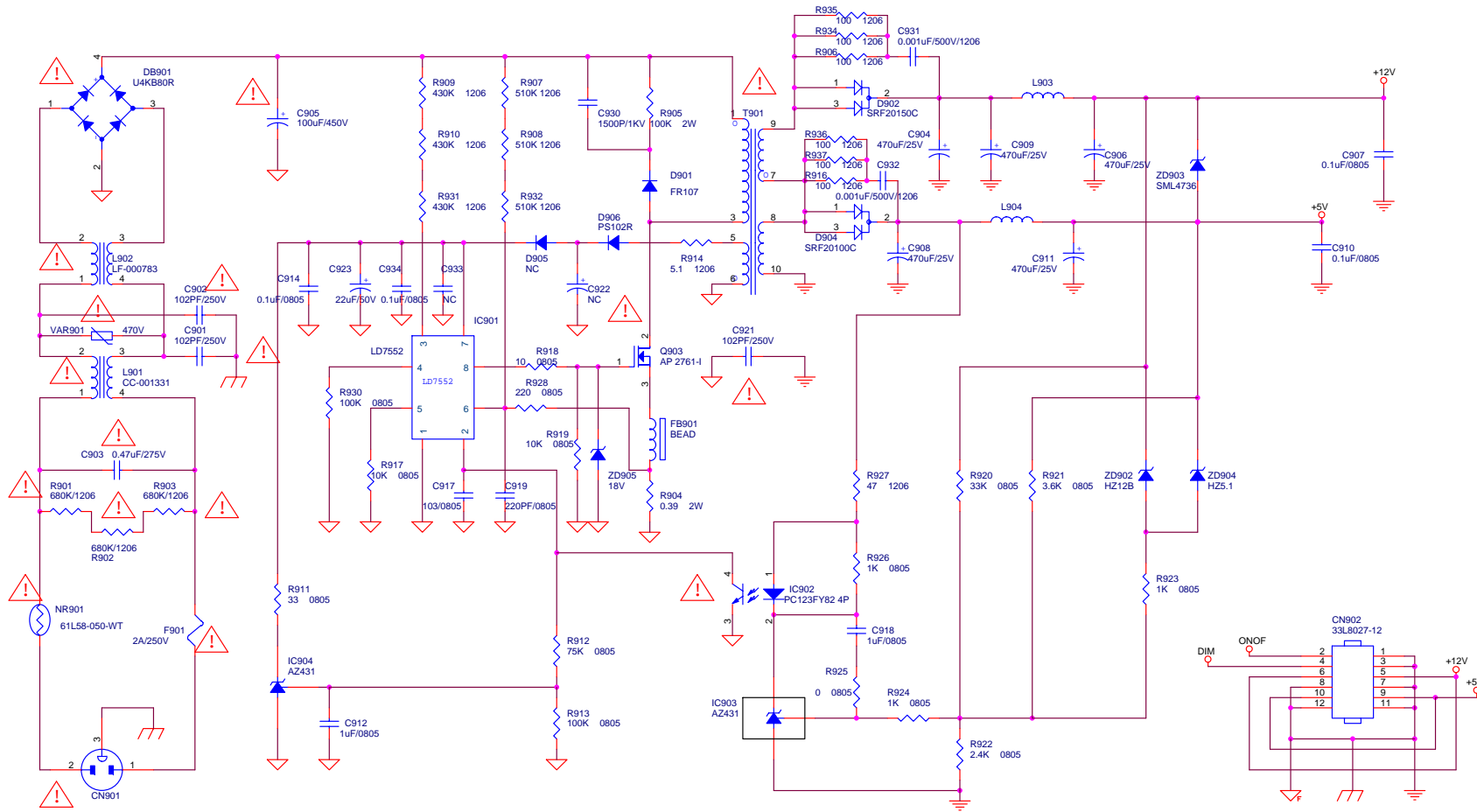

MODEL : PWPC1521LPH3

AOC (Top Victory) Electronics Co., Ltd.			
File			
1.POWER OUTPUT 12V & 5 V			
Size	Document Number	Rev	
B	HP 15"	B	
Date:	Wednesday, June 01, 2005	Sheet	1 of 2

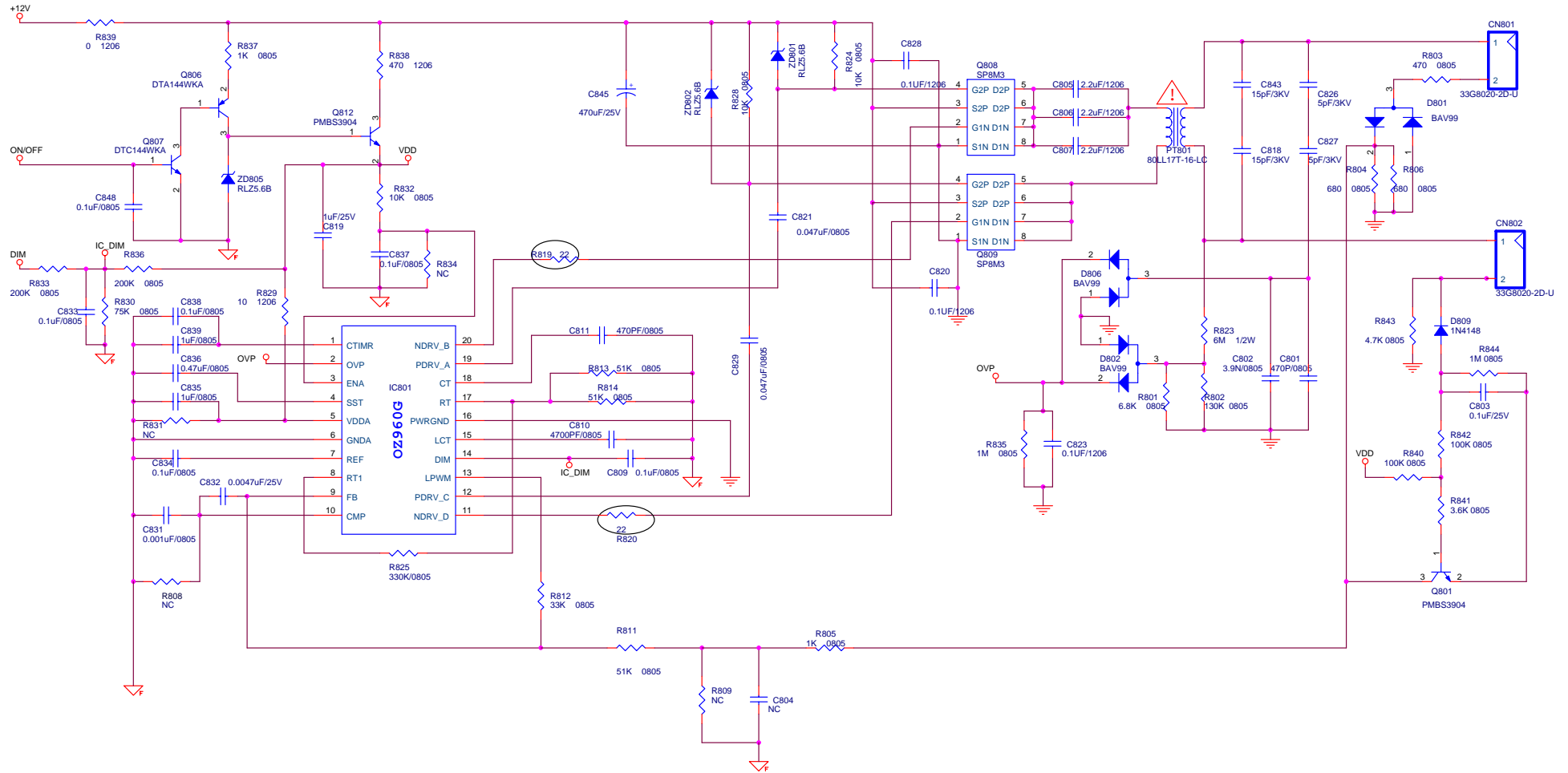

MODEL: PWPC1521LGH1
 PWPC1521CPH1
 PWPC1521HSH1

AOC (Top Victory) Electronics Co., Ltd.		
Title HP 15" (L1506)		
Size A3	Document Number Wednesday, June 01, 2005	Rev B
Date:	Sheet 2 of 2	

8. PCB Layout

8.1 MAIN BOARD (715G1533-D-MS)

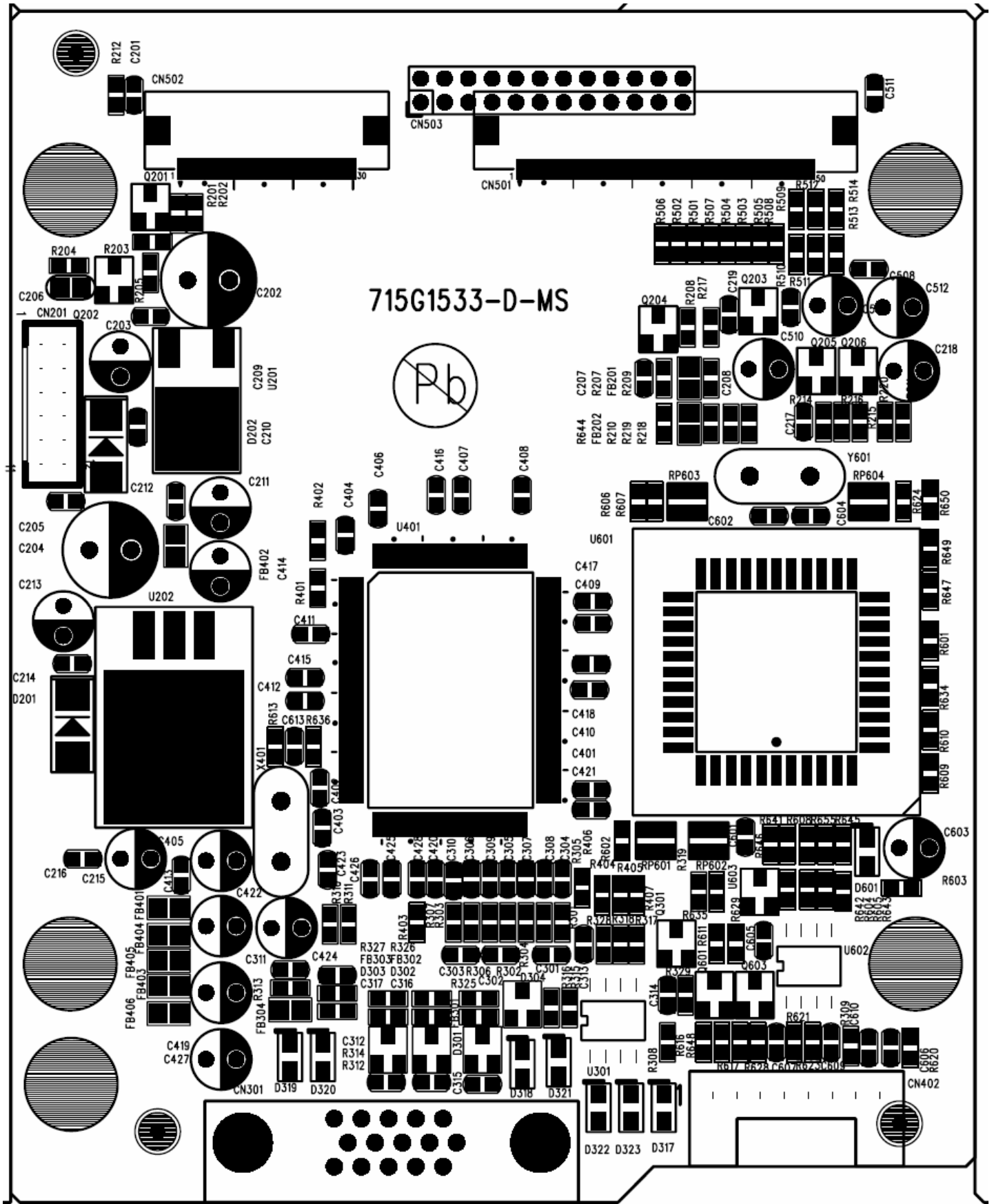

8.2 INVERTER / POWER BOARD (715G1508-1)

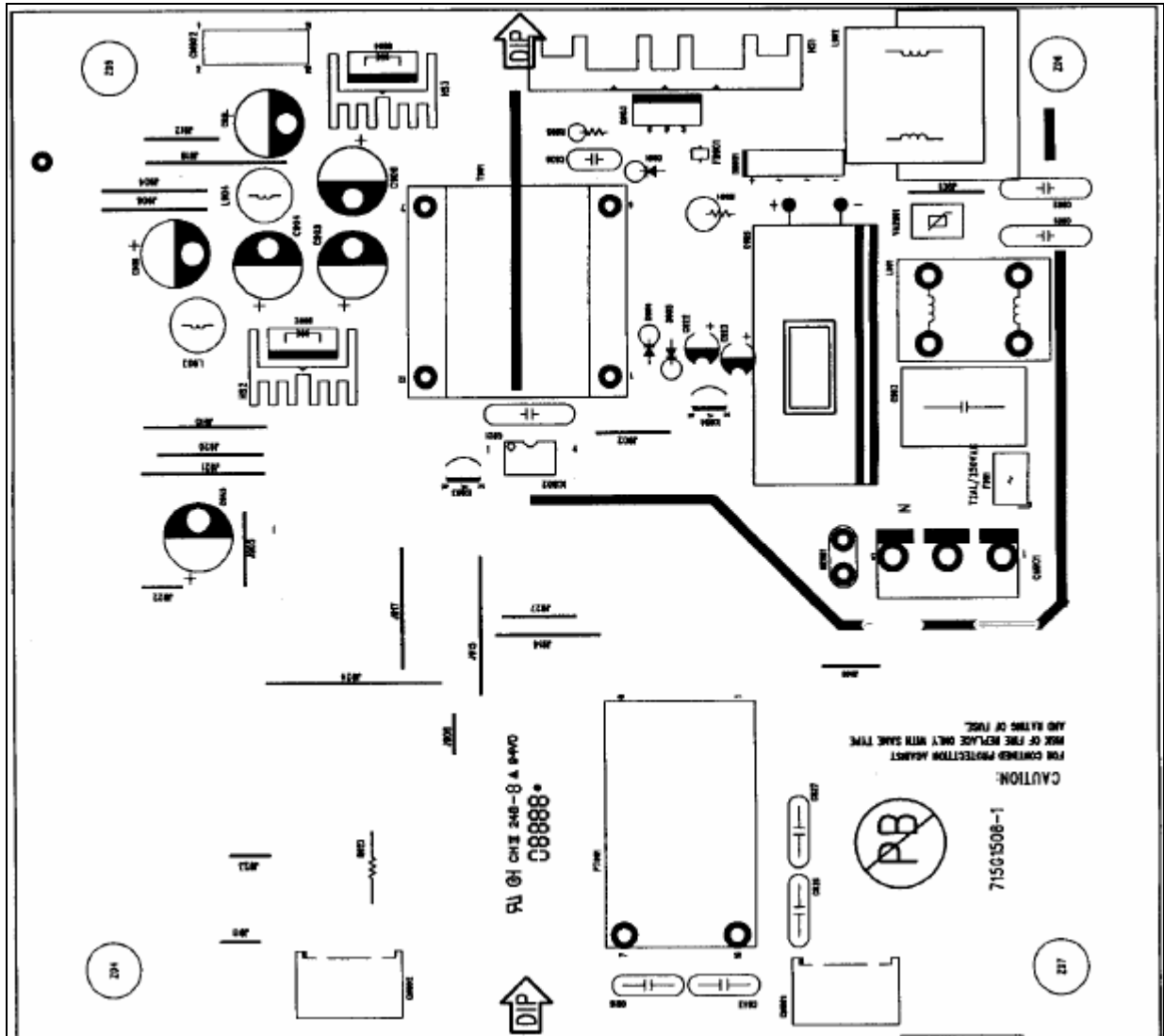

8.3 KEY BOARD

(715G1532-D1-P)

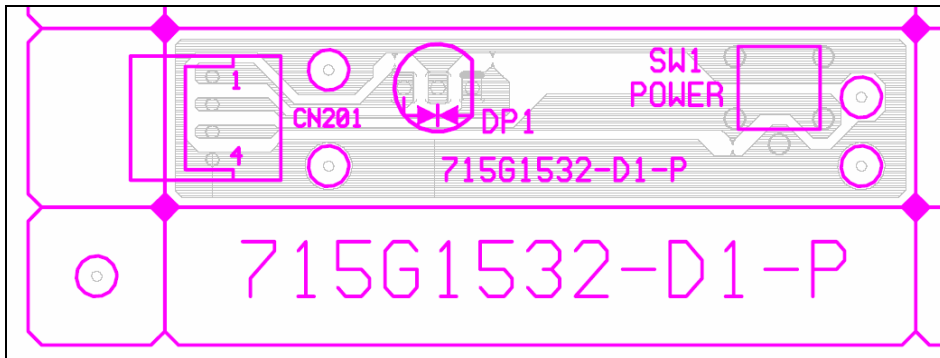

(715G1532-E-K)

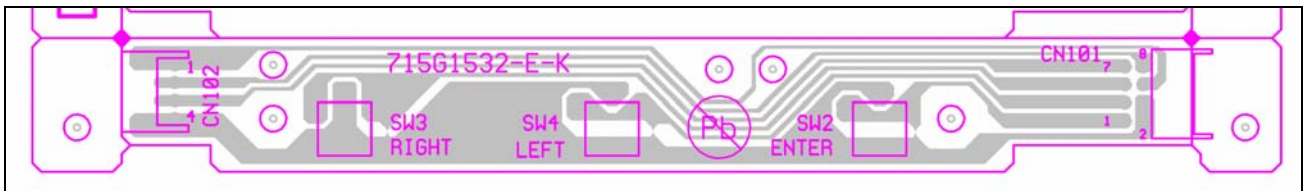

9. Maintainability

9.1 Equipments and Tools Requirement

- 1.) Multi-meter.
- 2.) Oscilloscope.
- 3.) Pattern Generator.
- 4.) DDC Tool with an IBM Compatible Computer.
- 5.) Alignment Tool.
- 6.) LCD Color Analyzer.
- 7.) Service Manual.
- 8.) User Manual.

9.2 Trouble Shooting

9.2.1 Main Board

No power

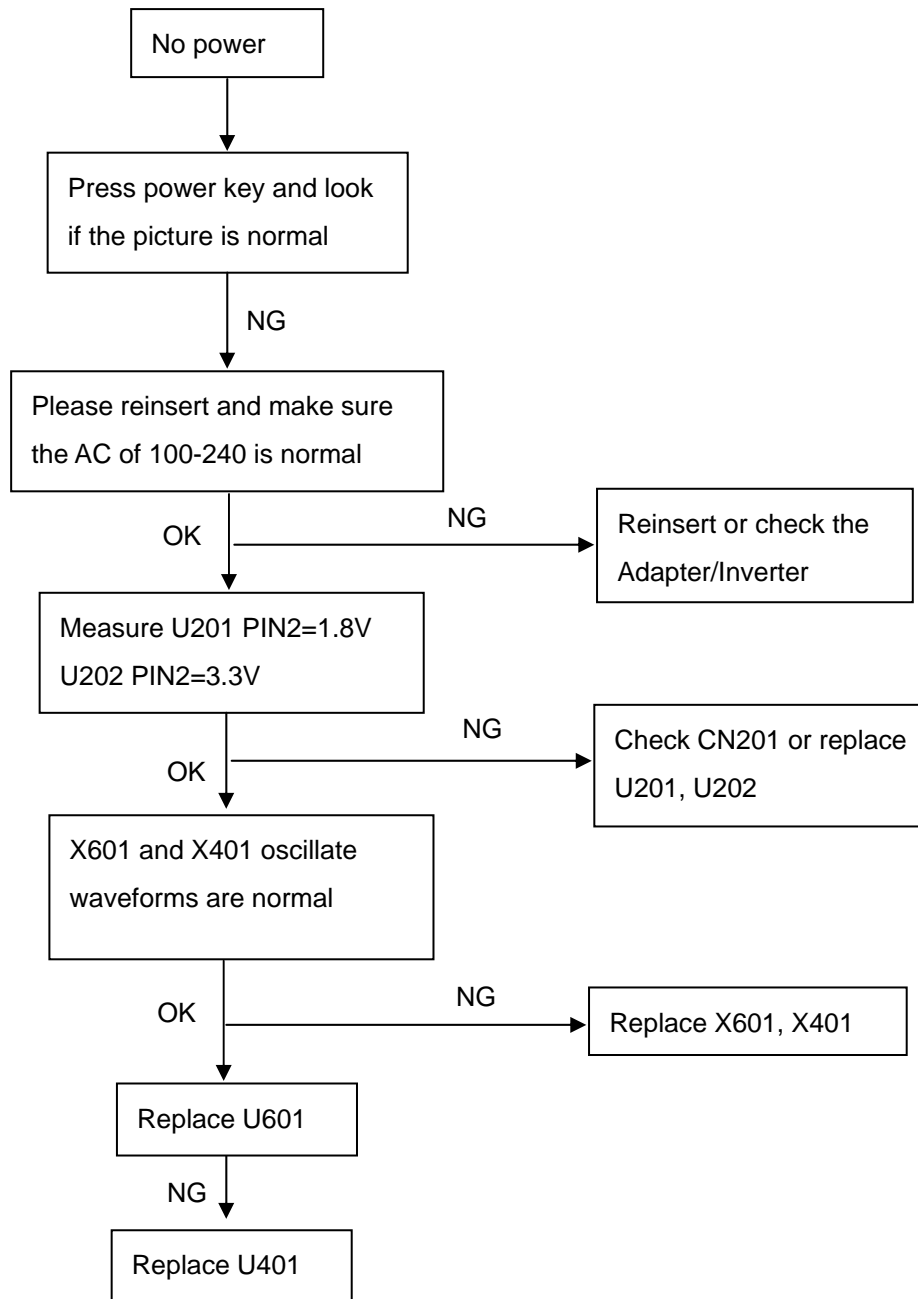

No picture (LED orange)

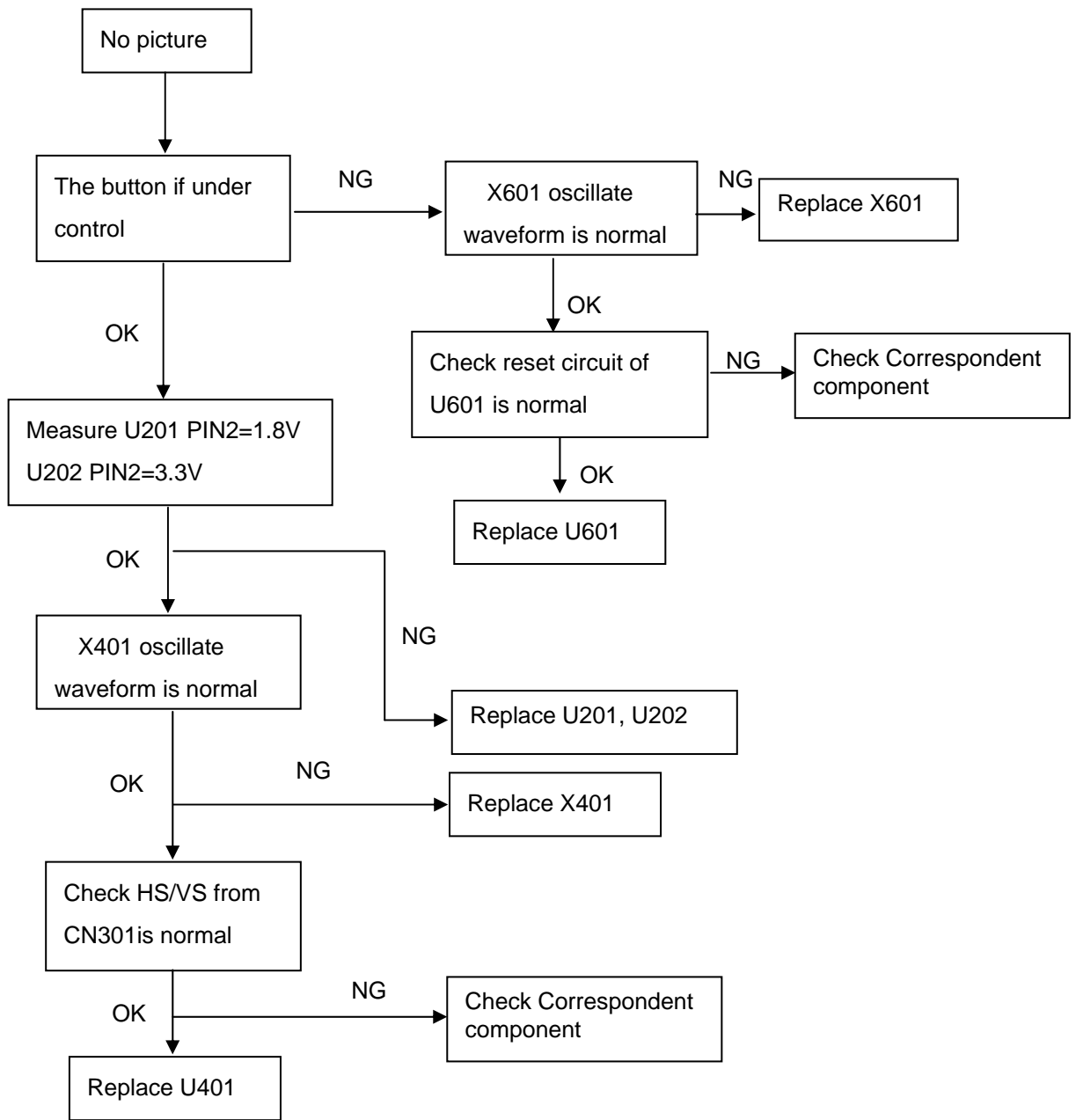

White screen

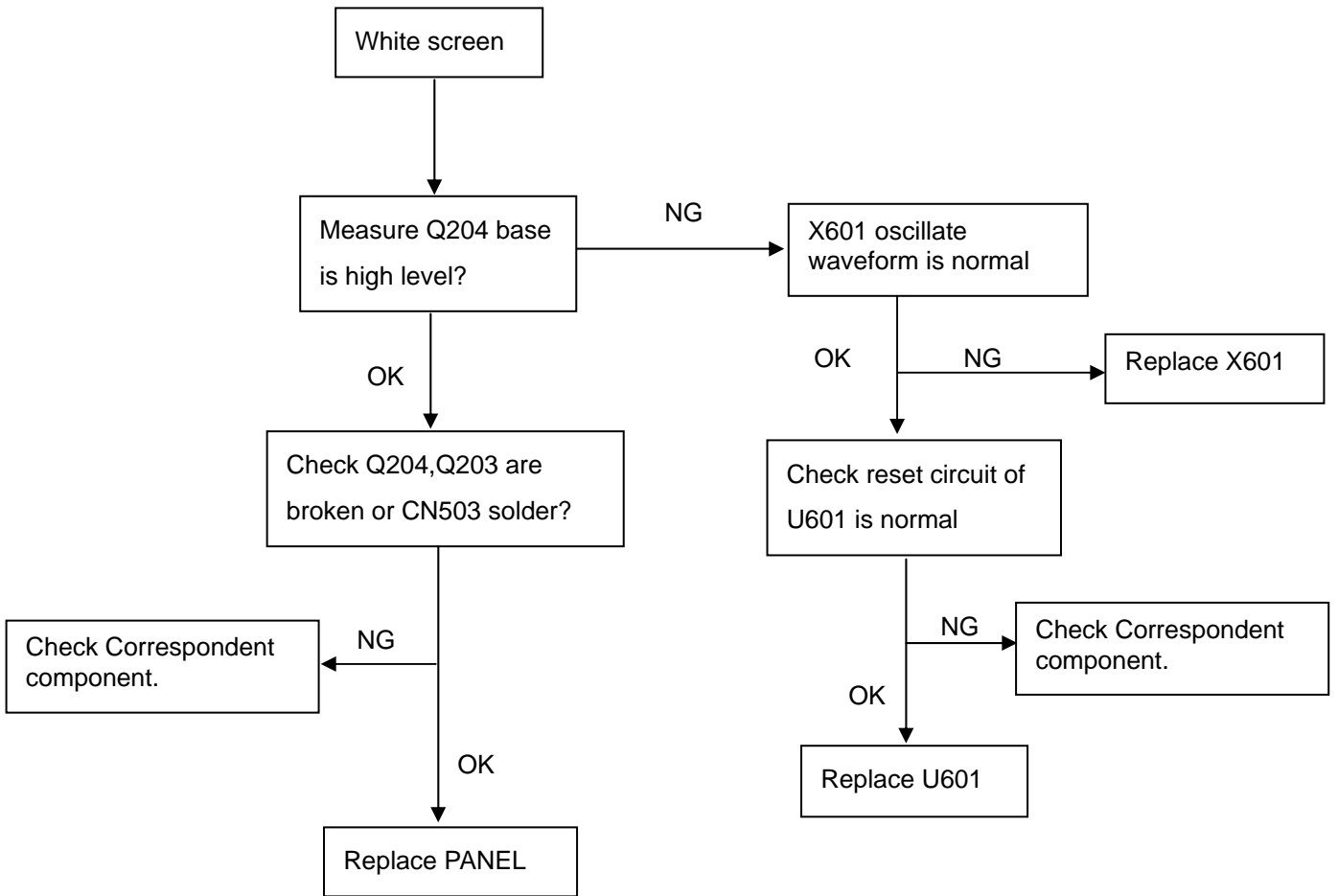

8.2.2 Inverter Board

No power

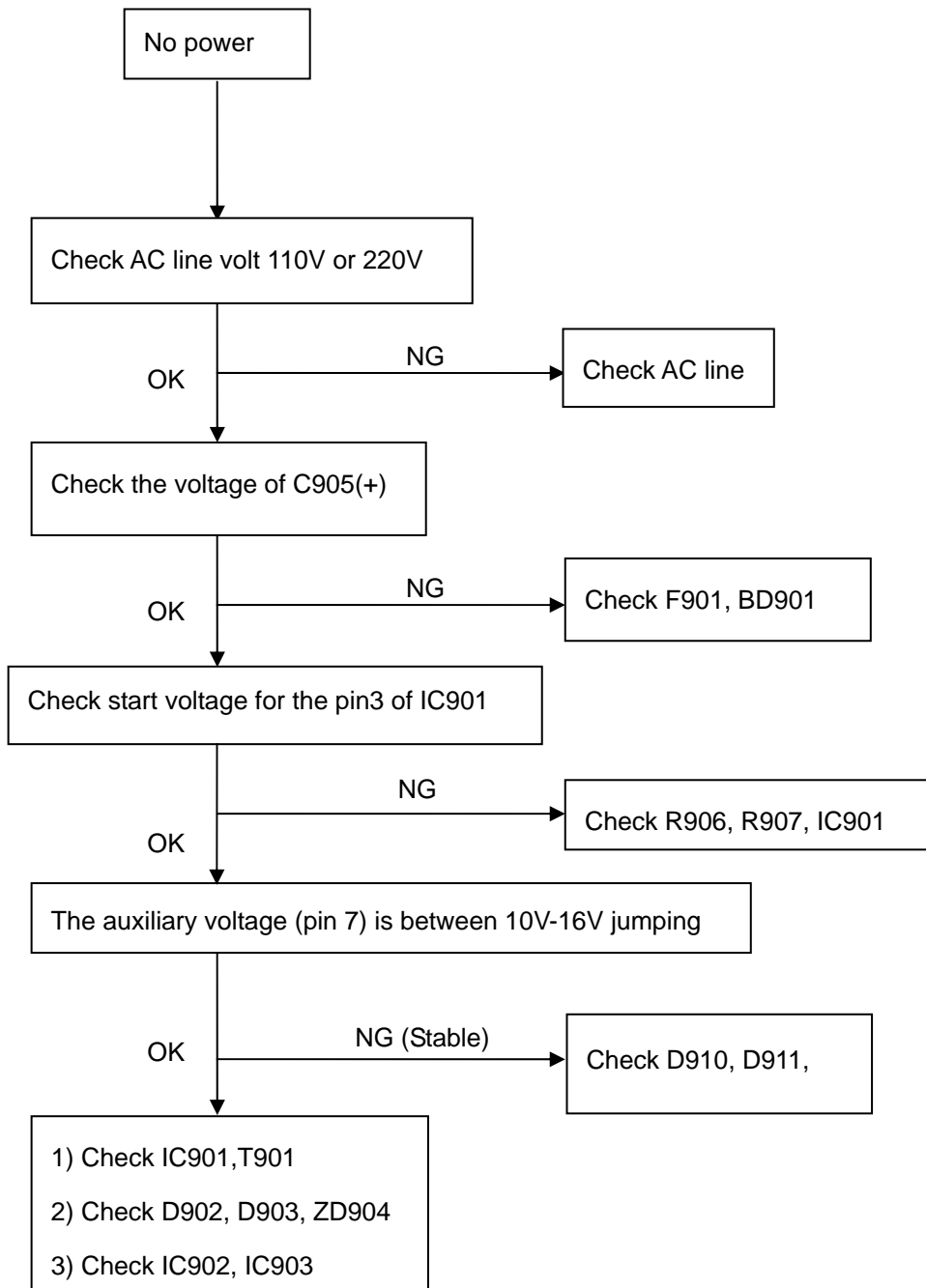

No backlight

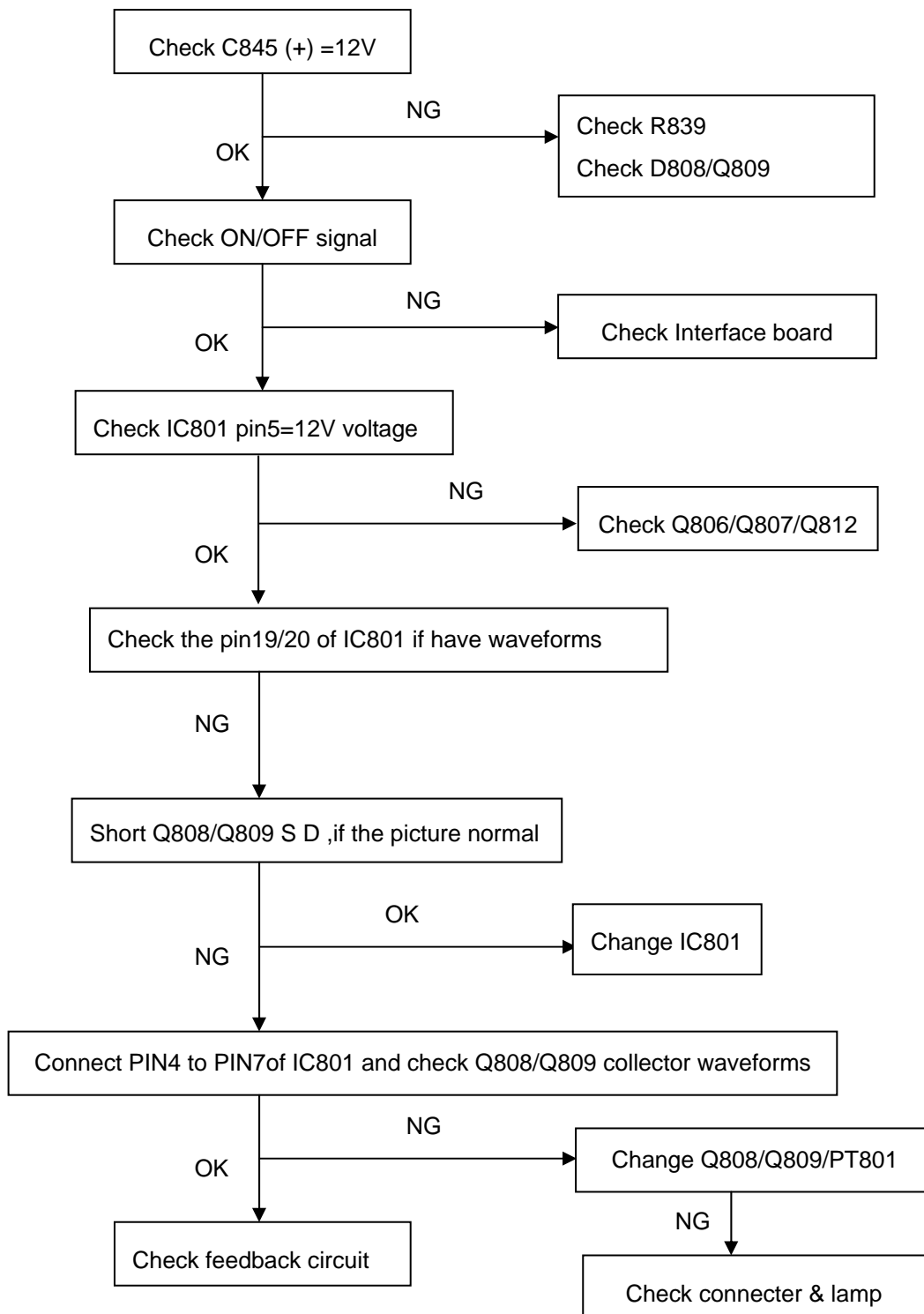

8.2.3 Key Pad Board

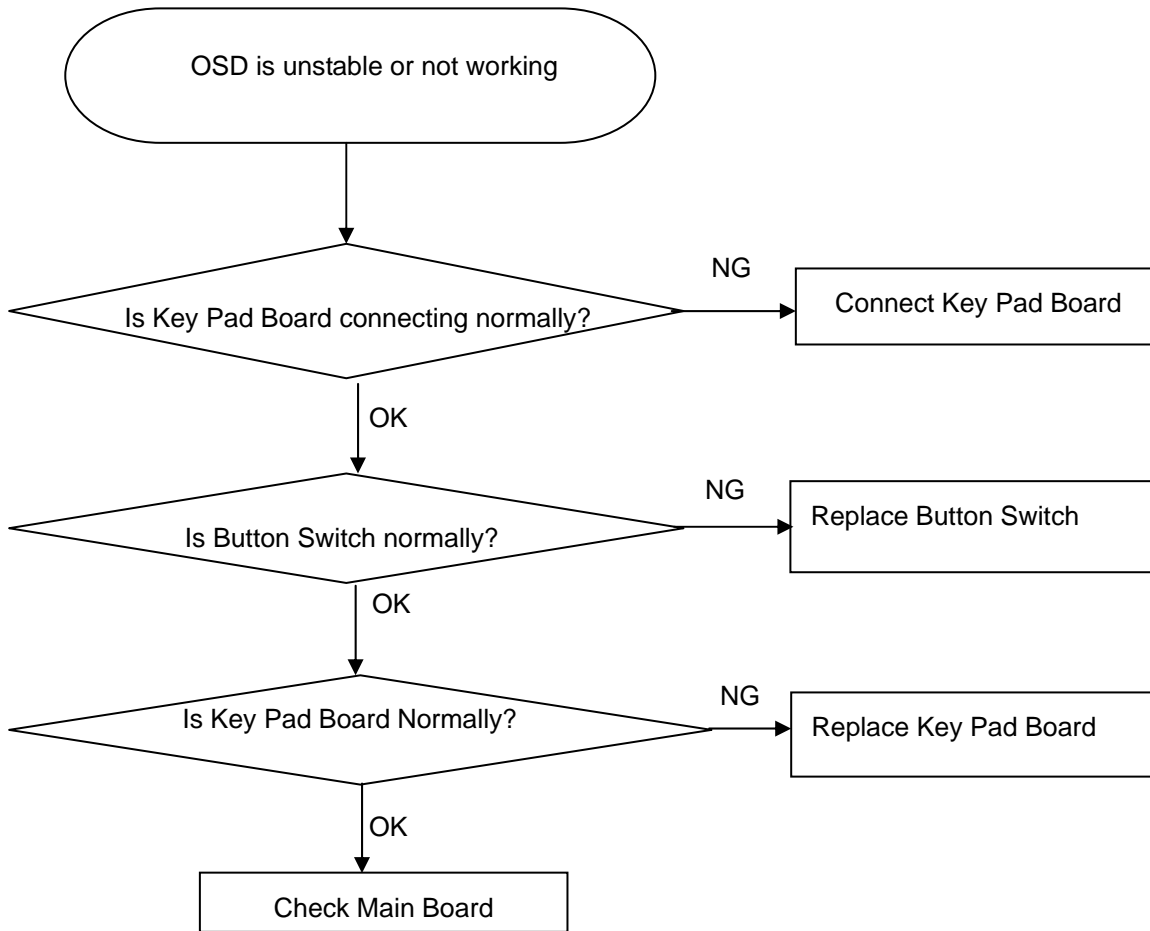

10. WHITE- BALANCE, LUMINANCE ADJUSTMENT

Approximately 30 minutes should be allowed for warm up before proceeding White-Balance adjustment.

1. How to do the Chroma-7120 MEM .Channel setting

A. Reference to chroma 7120 user guide

B. Use “ SC” key and “ NEXT” key to modify xyY value and use “ID” key to modify the

TEXT description Following is the procedure to do white-balance adjust

2. Setting the color temp. You want

A. 9300 color:

9300 color temp. parameter is $x = 283 \pm 20$, $y = 297 \pm 20$, $Y > 180 \text{ cd/m}^2$,

B. sRGB color:

sRGB color temp. parameter is $x = 313 \pm 20$, $y = 329 \pm 20$, $Y > 200 \text{ cd/m}^2$)

C. 6500K color:

Don't adjust, Custom requires.

3. Into factory mode of HP L1506

A. Press DOWN button during 2 seconds along with press Power button will activate the factory mode, then MCU will do AUTO LEVEL automatically. Meanwhile press MENU the OSD screen will located at THE LEFT TOP OF PANEL.

4. Bias adjustment:

Set the Contrast  to 80

Adjust the Brightness  to 90.

5. Gain adjustment :

Move cursor to “-F-” and press MENU key

A. Adjus 9300k color-temperature

1. Switch the Chroma-7120 to 9300k channel.

2. The chroma 7120 will show $x = 283 \pm 20$, $y = 297 \pm 20$, $Y > 180 \text{ cd/m}^2$

3. Switch the chroma-720 to RGB MODE (with press “MODE” button to change)

4. Adjust the RED of color 9300K on factory window until chroma 7120 indicator reached

the value R=100

5. Adjust the GREEN of color 9300K on factory window until chroma 7120 indicator reached

the value G=100

6. Adjust the BLUE of color 9300K on factory window until chroma 7120 indicator reached

the value B=100

7. Repeat above procedure (item 4,5,6) until chroma 7120 RGB value meet the

tolerance = 100 ± 2

B. Adjust sRGB color-temperature

1. Switch the chroma-7120 to sRGB channel.

2. The chroma 7120 will show $x = 313 \pm 20$, $y = 329 \pm 20$, $Y = 210 \pm 20$ cd/m²

3. Switch the chroma 7120 I to RGB MODE (with press "MODE" button to change)

4. Adjust the RED of color sRGB on factory window until chroma 7120 indicator reached

the value R=100

5. Adjust the GREEN of color sRGB on factory window until chroma 7120 indicator reached

the value G=100

6. Adjust the BLUE of color sRGB on factory window until chroma 7120 indicator reached

the value B=100

7. Repeat above procedure (item 4,5,6) until chroma 7120 RGB value meet the

tolerance = 100 ± 2

C. Press reset key and Turn the Power-button "off to on" to quit from factory mode.

11. Check List after replacing LCD Main board

I · Check if white-balance is within the specs after replacing Main board and panel, then re-writing DDC is necessary.

The white-balance value for each common color temperature:

9300 °K: $x=283 \pm 20$; $y = 297 \pm 20$;

sRGB: $x = 313 \pm 20$; $y = 329 \pm 20$;

The color temperature value above must be up to the situation of $x < y$. The value of Y should be confirmed according to different customers. 15" LCD is commonly 180 ± 20 cd/cm² (Center) and 17" LCD is required to be larger than 200 cd/cm² (Center). The exact brightness values are confirmed by the checking-regulations of different customers

and different models.

II. Steps of white-balance adjustment for LCD:(Take 17 ”HP LCD for example)

1. Required instruments: Chroma7120 \ Chroma2325 (BGA265A)。
2. First connect the instruments together and turn on the LCD power, then warm up for 30 minutes under full white screen mode. First press the “Reset” key in the menu to recover factory set as following.

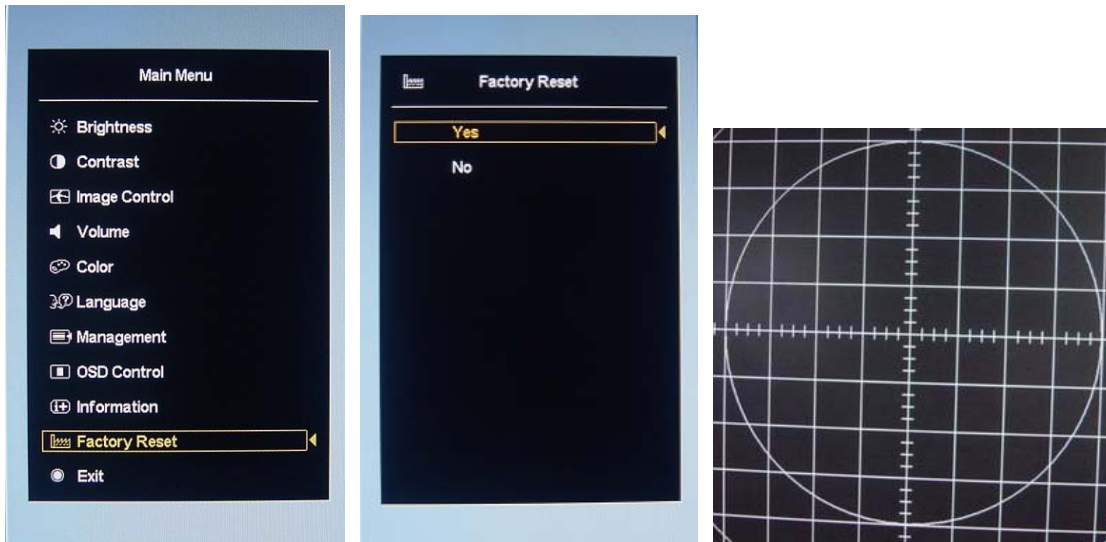

3. Set Chroma2325 at round-windows mode and make the detecting-head of Chroma7120 aim at the cross in the middle, the distance between the detecting-head and the cross is 20cm.
4. Set Chroma2325 (BGA265A) to be T144 (1280*1024/60HZ) and P105 of full white screen. Test if the white-balance value is within the specs. Please follow the steps below to adjust if it is beyond the specs.
5. Cut the power. Then press Down key and supply power at the same time to enter into the factory mode. See the following pictures.

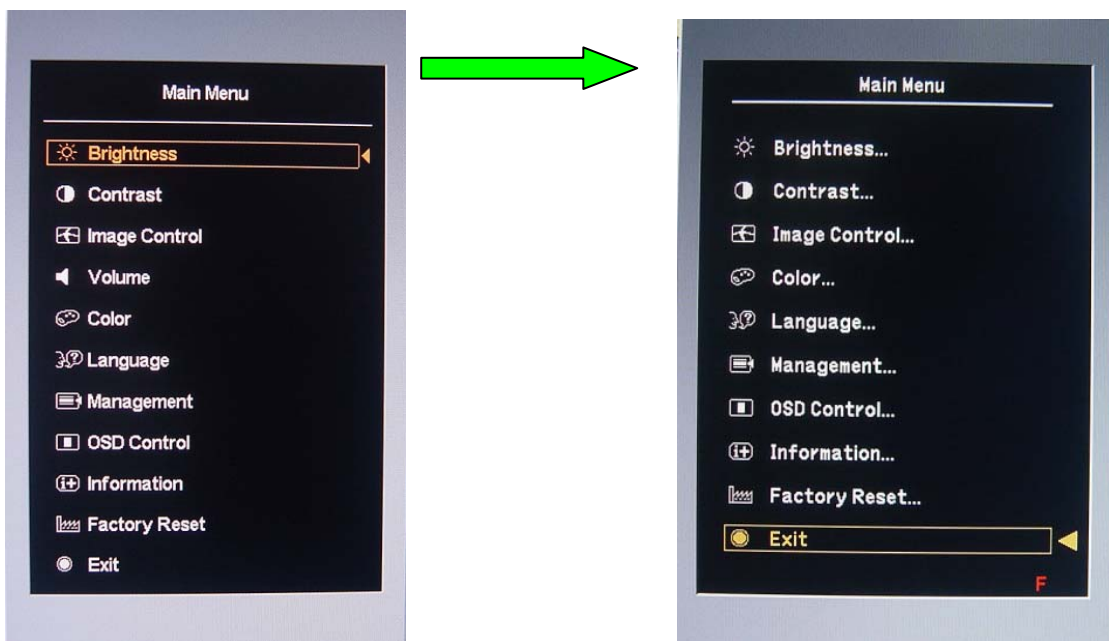

6. Test white-balance again after Auto Level. Adjustment with hand is necessary if it is beyond the specs just the same.

7. Select 7x00 item to adjust cool color-temperature and select 6x00 to adjust warm color- temperature. It can reach to the best effect through adjusting R/G/B value if it inclines to green or blue.
8. Select Exit to the upper menu after completing the adjustment. Then press POWER OFF to exit and save it.

III. Steps for writing DDC :

1. Employ PC, and connect the DDC-writing instrument and the instrument that is ready for writing into DDC to the power of 12v. Connect the signal cable of the latter to D-USB or DVI of DDC-writing instrument (The data-writing of monitor needs transfer-interface) and link the DDC-writing instrument with PC through printer interface. (See the schematic picture below)

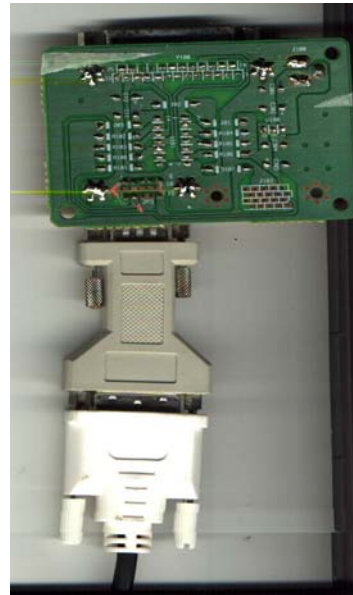

Connection of DDC-writing instrument for VGA.

2. Seek the document with the expanded name of .BAT in DDC file of this model. It appears the indication of “Input Serial No. : ” after dual-click the document to be ready for DDC-writing.

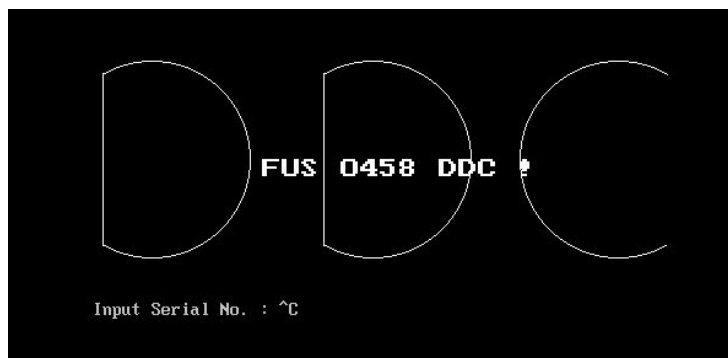

3. Input the serial number of the product (For instance: AOC LM729 is 13 bits), then press ENTER to start writing
4. Check the indication of DDC-writing program at the end. When you see the picture as the schematic picture above, the “Data compare OK!” means being written well and that’s the end. Please check if the Manufacturer Name, Vendor Assigned Code, Monitor Name, Serial Number, Week of Manufacture, Year of Manufacture are right. It will

appear “Data compare error !” to indicate failure if the DDC-writing doesn’t perform well. Please check the power resource and the connection of the signal cable, then return to step 3 by pressing ENTER and re-do it.

5.You can exit the program by pressing Ctrl plus C, then cut the signal cable and the power.

6.The following picture is taking Acer AL1721 EDID for example.

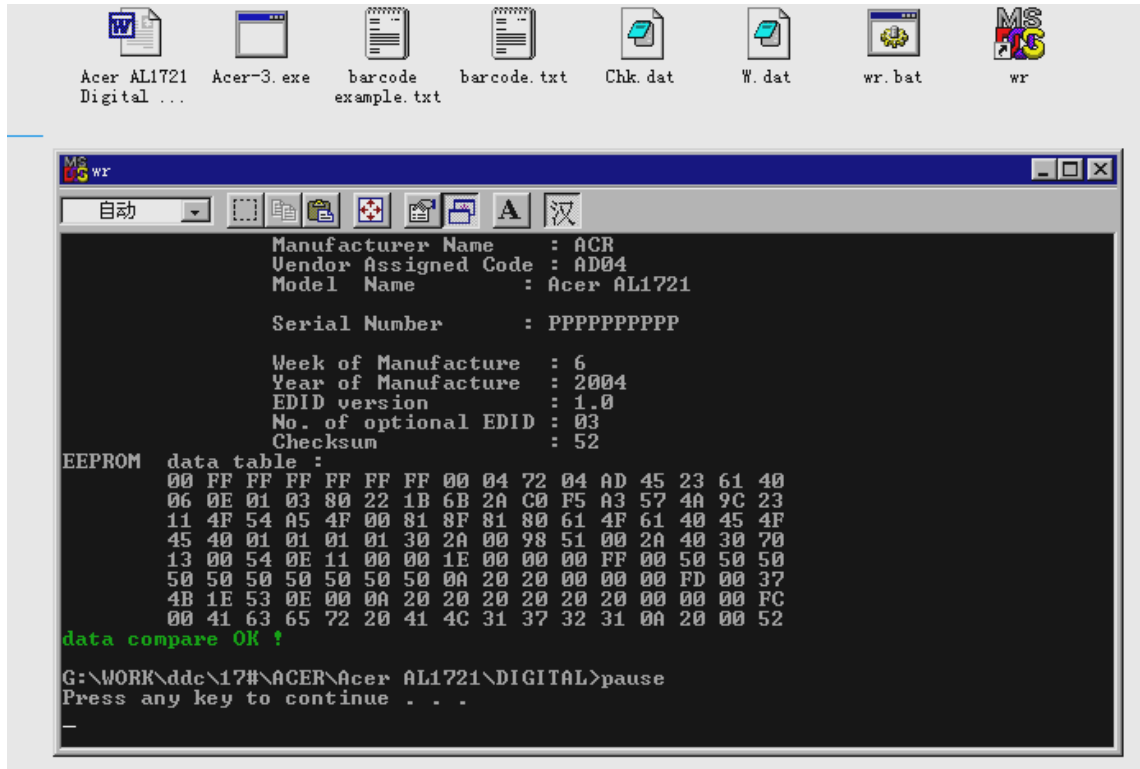

Notes:

- 1、Make sure the system time of PC is in accordance with the real time before writing.
- 2、The schematic picture is just as an example for description, the exact content of the DDC is dependent on the serial number of the BARCORD of this model.

3、Data DDC-writing needs a transfer interface.

Instruction : DDC-writing needs 4 files:

- 1. Barcode.txt (Supply Barcode length and flow number)
- 2. *.EXE (DDC-writing program)
- 3. WR.bat (Group order file for cycling utilization of *.EXE, and dual-click this file when perform DDC-writing)
- 4. w.dat The content with 128 bits of DDC

12. EDID

	00	01	02	03	04	05	06	07	08	09	10	11	12	13	14	15
0:	00	FF	FF	FF	FF	FF	FF	00	22	F0	5B	26	01	01	01	01
16:	0B	0F	01	03	68	1E	16	8C	EE	B4	60	A1	58	4E	97	26
32:	16	50	54	AD	EE	00	01	01	01	01	01	01	01	01	01	01
48:	01	01	01	01	01	01	64	19	00	40	41	00	26	30	18	88
64:	36	00	2C	DC	10	00	00	18	00	00	00	FD	00	32	4C	1E
80:	3F	08	00	0A	20	20	20	20	20	20	00	00	00	FC	00	48
96:	50	20	4C	31	35	30	36	0A	20	20	20	20	00	00	00	FF
112:	00	43	4E	43	35	31	31	30	30	30	31	0A	20	20	00	EF

13. BOM List

T560KC4DKHHPNP

Location	Part No. for TPV	Description
	CBPC560KC4HPNP	CONVERSION BOARD
	KEPC560KHP5P	KEY BOARD
	KEPC980KHP4P	KEY BOARD
	PWPC1521CPH1P	POWER BOARD
	15G8159 3	MAIN FRAME
	33G4856 EY L	LOGO PLATE
	33G4889 EY L	STAND CAP
	34G1563 EY B	REAR COVER
	44G3583 1	EPS
	44G3583 2	EPS
	44G3583 3EPE	EPE
	44G3583624 1A	CARTON
	45G 88606 H	PE BAG FOR BASE
	45G 88607 H	PE BAG FOR MONITOR
	45G 88609 1	EPE COVER
	52G 1186	SMALL TAPE
	52G6022 1500	SMALL TAPE
	52G6025 11898	MYLAR
	71L 100521	CORE
	85G 692 1	SHIELD
	89G1738GAA 21	D-SUB CABLE
	89G176N 50 19	FFC 50PIN 180MM
	89G402A19N IS	AC POWER CABLE
	95G8014 8 30	HARNESS 160MM 8P-8P
	M1G 130 5225	SCREW
	M1G 330 4120	SCREW
	M1G 340 8 47	SCREW
	M1G1730 6128	SCREW M3x6
	M1G1730 6128	SCREW M3x6
	M1G1740 6128	SCREW
	M1G3030 5 47	SCREW
	Q1G 330 6120	SCREW

	Q1G 330 6120	SCREW
	705G560KC87 02	AC SOCKET ASS'Y
	705G560KF34002	15" LCD ASS'Y
	705G560KP34005	15" LCD ASS'Y
	750GLC50P021HZ	CPT 15" 030 ZDB PANEL
	AIC560KC4HPNP	MAIN BOARD
	40G 457624 1B	LABEL-CPU
	40G 45762412B	CBPC LABEL
C202	67G215B221 4H	LOW E.S.R 220UF +-20% 2
C204	67G215B221 4H	LOW E.S.R 220UF +-20% 2
C208	67G309V100 3	10uf =_20% 16v
C211	67G309V470 3	47UF 16V 85C
C213	67G309V470 3	47UF 16V 85C
C215	67G309V470 3	47UF 16V 85C
C405	67G309V100 3	10uf =_20% 16v
C414	67G309V100 3	10uf =_20% 16v
C419	67G309V100 3	10uf =_20% 16v
C422	67G309V100 3	10uf =_20% 16v
C424	67G309V100 3	10uf =_20% 16v
C427	67G309V100 3	10uf =_20% 16v
C509	67G305S220 3H	22UF 16V MINI TYPE
C603	67G309V100 3	10uf =_20% 16v
CN201	33G8027 12	WAFER 2*6P 2.0MM R/A
CN301	88G 35315F H	D-SUB 15PIN
CN402	33G3802 8H	WAFER 8P RIGHT ANGLE PI
X401	93G 22 53	CRYSTAL 14.318MHzHC-49U
Y601	93G 22 45 J	24MHZ/30PF/49US
	715G1533 D MS	MAIN BOARD PCB
C201	65G0603104 32	CHIP 0.1UF 50V X7R
C203	65G0603104 32	CHIP 0.1UF 50V X7R
C205	65G0603104 32	CHIP 0.1UF 50V X7R
C206	65G0805105 37	CHIP 1UF 50V Y5V
C207	65G0603104 32	CHIP 0.1UF 50V X7R
C210	65G0603104 32	CHIP 0.1UF 50V X7R
C212	65G0603104 32	CHIP 0.1UF 50V X7R
C214	65G0603104 32	CHIP 0.1UF 50V X7R
C216	65G0603104 32	CHIP 0.1UF 50V X7R

C219	65G0603104 32	CHIP 0.1UF 50V X7R
C304	65G0603473 32	CHIP 0.047UF 50V X7R
C305	65G0603473 32	CHIP 0.047UF 50V X7R
C306	65G0603473 32	CHIP 0.047UF 50V X7R
C307	65G0603102 32	1000PF +-10% 50V X7R
C308	65G0603473 32	CHIP 0.047UF 50V X7R
C309	65G0603473 32	CHIP 0.047UF 50V X7R
C310	65G0603473 32	CHIP 0.047UF 50V X7R
C311	65G0603680 31	CHIP 68PF 50V NPO
C312	65G0603221 32	CHIP 220PF 50V NPO
C313	65G0603224 32	CHIP 0.22UF 50V X7R
C314	65G0603104 12	CER2 0603 X7R 16V 100N
C315	65G0603104 32	CHIP 0.1UF 50V X7R
C316	65G0603104 32	CHIP 0.1UF 50V X7R
C317	65G0603104 32	CHIP 0.1UF 50V X7R
C401	65G0603104 32	CHIP 0.1UF 50V X7R
C402	65G0603220 31	CER1 0603 NP0 50V 22P P
C403	65G0603220 31	CER1 0603 NP0 50V 22P P
C404	65G0603104 32	CHIP 0.1UF 50V X7R
C406	65G0603104 32	CHIP 0.1UF 50V X7R
C407	65G0603104 32	CHIP 0.1UF 50V X7R
C408	65G0603104 32	CHIP 0.1UF 50V X7R
C409	65G0603104 32	CHIP 0.1UF 50V X7R
C410	65G0603104 32	CHIP 0.1UF 50V X7R
C411	65G0603104 32	CHIP 0.1UF 50V X7R
C412	65G0603104 32	CHIP 0.1UF 50V X7R
C413	65G0603104 32	CHIP 0.1UF 50V X7R
C415	65G0603104 32	CHIP 0.1UF 50V X7R
C416	65G0603104 32	CHIP 0.1UF 50V X7R
C417	65G0603104 32	CHIP 0.1UF 50V X7R
C418	65G0603104 32	CHIP 0.1UF 50V X7R
C420	65G0603104 32	CHIP 0.1UF 50V X7R
C421	65G0603104 32	CHIP 0.1UF 50V X7R
C423	65G0603104 32	CHIP 0.1UF 50V X7R
C425	65G0603104 32	CHIP 0.1UF 50V X7R
C426	65G0603104 32	CHIP 0.1UF 50V X7R
C428	65G0603104 32	CHIP 0.1UF 50V X7R

C510	65G0603104 32	CHIP 0.1UF 50V X7R
C511	65G0603104 32	CHIP 0.1UF 50V X7R
C601	65G0603104 32	CHIP 0.1UF 50V X7R
C602	65G0603220 31	CER1 0603 NP0 50V 22P P
C604	65G0603220 31	CER1 0603 NP0 50V 22P P
C605	65G0603224 32	CHIP 0.22UF 50V X7R
C606	65G0603102 32	1000PF +-10% 50V X7R
C607	65G0603102 32	1000PF +-10% 50V X7R
C609	65G0603102 32	1000PF +-10% 50V X7R
C610	65G0603102 32	1000PF +-10% 50V X7R
C613	65G0603104 32	CHIP 0.1UF 50V X7R
CN501	33G8019 50	CONNECTOR 50P
D201	93G1004 3	SS14
D202	93G1020 1 S	GS1D
D301	93G 6433P	BAV99
D302	93G 6433P	BAV99
D303	93G 6433P	BAV99
D304	93G 64 42 P	BAV70 SOT-23
D317	93G 39149	MLL5232B BY FULL POWER
D318	93G 39149	MLL5232B BY FULL POWER
D319	93G 39149	MLL5232B BY FULL POWER
D320	93G 39149	MLL5232B BY FULL POWER
D321	93G 39149	MLL5232B BY FULL POWER
D322	93G 39149	MLL5232B BY FULL POWER
D323	93G 39149	MLL5232B BY FULL POWER
D601	93G 64 44 S	LL4148WP
FB202	71G 56Z601	CHIP BEAD 600 OHM 0805
FB301	61L0603000	RST SM 0603 JUMP MAX 0R
FB302	61L0603000	RST SM 0603 JUMP MAX 0R
FB303	61L0603000	RST SM 0603 JUMP MAX 0R
FB304	61L0805201	200 OHM 0805 1/8W
FB401	71G 56Z601	CHIP BEAD 600 OHM 0805
FB402	71G 56Z601	CHIP BEAD 600 OHM 0805
FB403	71G 56Z601	CHIP BEAD 600 OHM 0805
FB404	71G 56Z601	CHIP BEAD 600 OHM 0805
FB405	71G 56Z601	CHIP BEAD 600 OHM 0805
FB406	71G 56Z601	CHIP BEAD 600 OHM 0805

Q201	57G 417 4	PMBS3904/PHILIPS-SMT(04
Q202	57G 417 4	PMBS3904/PHILIPS-SMT(04
Q203	57G 763 1	A03401 SOT23 BY AOS(A1)
Q204	57G 417 4	PMBS3904/PHILIPS-SMT(04
Q301	57G 417 4	PMBS3904/PHILIPS-SMT(04
Q601	57G 417 6	PMBS3906/PHILIPS-SMT(06
Q603	57G 417 6	PMBS3906/PHILIPS-SMT(06
R201	61L0603472	RST SM 0603 RC0603 4K7
R202	61L0603103	RST SM 0603 RC0603 10K
R203	61L0603102	RST SM 0603 RC0603 1K P
R204	61L0603103	RST SM 0603 RC0603 10K
R205	61L0603472	RST SM 0603 RC0603 4K7
R207	61L0603472	RST SM 0603 RC0603 4K7
R208	61L0603103	RST SM 0603 RC0603 10K
R210	61L0603000	RST SM 0603 JUMP MAX 0R
R211	61L0603103	RST SM 0603 RC0603 10K
R212	61L0603472	RST SM 0603 RC0603 4K7
R217	61L0603513	CHIP 51K OHM 1/10W
R218	61L0603103	RST SM 0603 RC0603 10K
R219	61L0603103	RST SM 0603 RC0603 10K
R301	61L0603330	CHIPR 33 OHM +-5% 1/10W
R302	61L0603330	CHIPR 33 OHM +-5% 1/10W
R303	61L0603330	CHIPR 33 OHM +-5% 1/10W
R304	61L0603471	CHIPR 470 OHM+-5% 1/10W
R305	61L0603680	RST SM 0603 RC0603 68R
R306	61L0603680	RST SM 0603 RC0603 68R
R307	61L0603680	RST SM 0603 RC0603 68R
R308	61L0603103	RST SM 0603 RC0603 10K
R309	61L0603101	RST SM 0603 RC0603 100R
R310	61L0603102	RST SM 0603 RC0603 1K P
R311	61L0603102	RST SM 0603 RC0603 1K P
R312	61L0603101	RST SM 0603 RC0603 100R
R313	61L0603222	RST SM 0603 RC0603 2K2
R314	61L0603222	RST SM 0603 RC0603 2K2
R315	61L0603220	RST SM 0603 RC0603 22R
R316	61L0603220	RST SM 0603 RC0603 22R
R317	61L0603472	RST SM 0603 RC0603 4K7

R318	61L0603472	RST SM 0603 RC0603 4K7
R319	61L0603223	CHIPR 22K OHM +-5% 1/10
R325	61L0603750	RST SM 0603 RC22H 75R P
R326	61L0603750	RST SM 0603 RC22H 75R P
R327	61L0603750	RST SM 0603 RC22H 75R P
R328	61L0603472	RST SM 0603 RC0603 4K7
R329	61L0603103	RST SM 0603 RC0603 10K
R402	61L0603472	RST SM 0603 RC0603 4K7
R403	61L0603390 0F	CHIP 390 OHM 1/10W 1%
R501	61L0603000	RST SM 0603 JUMP MAX 0R
R502	61L0603000	RST SM 0603 JUMP MAX 0R
R503	61L0603000	RST SM 0603 JUMP MAX 0R
R504	61L0603000	RST SM 0603 JUMP MAX 0R
R505	61L0603000	RST SM 0603 JUMP MAX 0R
R506	61L0603000	RST SM 0603 JUMP MAX 0R
R507	61L0603000	RST SM 0603 JUMP MAX 0R
R508	61L0603000	RST SM 0603 JUMP MAX 0R
R510	61L0603000	RST SM 0603 JUMP MAX 0R
R601	61L0603103	RST SM 0603 RC0603 10K
R602	61L0603103	RST SM 0603 RC0603 10K
R603	61L0603103	RST SM 0603 RC0603 10K
R604	61L0603103	RST SM 0603 RC0603 10K
R605	61L0603103	RST SM 0603 RC0603 10K
R606	61L0603103	RST SM 0603 RC0603 10K
R607	61L0603103	RST SM 0603 RC0603 10K
R608	61L0603101	RST SM 0603 RC0603 100R
R609	61L0603101	RST SM 0603 RC0603 100R
R610	61L0603101	RST SM 0603 RC0603 100R
R611	61L0603101	RST SM 0603 RC0603 100R
R613	61L0603103	RST SM 0603 RC0603 10K
R616	61L0603472	RST SM 0603 RC0603 4K7
R617	61L0603471	CHIPR 470 OHM+-5% 1/10W
R620	61L0603102	RST SM 0603 RC0603 1K P
R621	61L0603102	RST SM 0603 RC0603 1K P
R623	61L0603102	RST SM 0603 RC0603 1K P
R624	61L0603102	RST SM 0603 RC0603 1K P
R628	61L0603471	CHIPR 470 OHM+-5% 1/10W

R629	61L0603472	RST SM 0603 RC0603 4K7
R636	61L0603101	RST SM 0603 RC0603 100R
R641	61L0603000	RST SM 0603 JUMP MAX 0R
R644	61L0603103	RST SM 0603 RC0603 10K
R645	61L0603103	RST SM 0603 RC0603 10K
R655	61L0603103	RST SM 0603 RC0603 10K
RP601	61L 125103 8	CHIP AR 8P4R 10KOHM +-5
RP602	61L 125103 8	CHIP AR 8P4R 10KOHM +-5
RP603	61L 125103 8	CHIP AR 8P4R 10KOHM +-5
RP604	61L 125103 8	CHIP AR 8P4R 10KOHM +-5
U201	56G 563 31	AI1117D-1.8-EI
U202	56G 563 7	AIC1084-33PM
U301	56G1133 34	M24C02-WMN6TP
U401	56G 562511	TSU15AK-LF
U601	56G1125543CH4	MTV512GMV
U602	56G113356A	24LC16B/SNG SOIC-8PIN
	715G1532 D1 P	KEPC PCB
CN201	95G8014 4515	HARNESS
DP1	81G 12 1 GP	GP32032ME
SW1	77G 600 1GCJ	TACT SWITCH TSPB-2
	715G1532 E K	KEPC PCB
CN101	33G8027 8 H	WAFER 8P 2.0mm DIP DUAL
CN102	33G3802 4H	WAFER 4P RIGHT ANGLE
SW2	77G 600 1GCJ	TACT SWITCH TSPB-2
SW3	77G 600 1GCJ	TACT SWITCH TSPB-2
SW4	77G 600 1GCJ	TACT SWITCH TSPB-2
	40G 45762420A	ID LABEL
	705G 560 57 43	Q903 ASS'Y
	705G 560 93 01	D902 ASS'Y
	705G 560 93 02	D904 ASS'Y
	705G 780 61 09	R905 ASS'Y
C818	65L 3J1506ET	15PF 3KV 5%
C826	65L 3J5096ET	5PF 5% SL 3KV
C827	65L 3J5096ET	5PF 5% SL 3KV
C843	65L 3J1506ET	15PF 3KV 5%
C845	67G215S102 3K	ED1000UF 16V
C901	65G305M2222BP	2200PF +-20%

C902	65G305M2222BP	2200PF +-20%
C904	67G215S471 3K	EC 470UF 16V
C905	67G215S10115K	100UF 450V
C906	67G215S471 3K	EC 470UF 16V
C908	67G215S471 3K	EC 470UF 16V
C909	67G215S471 3K	EC 470UF 16V
C911	67G215S471 3K	EC 470UF 16V
C921	65G306M4722BP	4700PF +-20% 400VAC
CN801	33G8020 2D U	WAFER
CN802	33G8020 2D U	WAFER
CN901	33G8029 5A	WAFER
CN902	95G8014 12517	CONNECTOR
D901	93G 6026T52T	RECTIFIER DIODE FR107
D906	93G 6038T52T	FR103
DB901	93G 50460 13	BRKDGE KBP206G 2A 600V
FB901	71G 55 29	FERRITE BEAD
IC902	56G 139 3A	PC123Y22
L901	73L 174 55 HG GP	GBQM4.778.392
L902	73L 174 40LSG GP	LINE FILTER
L903	73G 253 91 LS	CHOKE BY LI SHIN
L904	73G 253 91 LS	CHOKE BY LI SHIN
NR901	61G 58080 WT	8 OHM NCT
PT801	80GL15T 20 DN	TRANSFORMER
R904	61G152M39858F	0.39 OHM 5% 2W
T901	80GL15T 19 N	TRANSFORMER BY YUVA
	PW1521CPH1AIP	POWER BOARD FOR AI
C801	65G0805471 31	CHIP 470PF 50V NPO
C802	65G0805392 31	CHIP 3900PF 50V X7R 080
C803	65G0805104 22	0.1UF +-10% 25V X7R 080
C805	65G1206225 22	2.2UF 25V X7R 1206
C806	65G1206225 22	2.2UF 25V X7R 1206
C807	65G1206225 22	2.2UF 25V X7R 1206
C810	65G0805472 31	CHIP 4700PF 50V X7R 080
C811	65G0805471 21	CHIP 470PF 25V NPO
C819	65G0805105 22	CHIP 1UF 25V X7R 0805
C820	65G0805104 22	0.1UF +-10% 25V X7R 080
C821	65G0805473 22	SMD 47nf +-10%25V XTR

C823	65G0805104 22	0.1UF +-10% 25V X7R 080
C828	65G0805104 22	0.1UF +-10% 25V X7R 080
C829	65G0805473 22	SMD 47nf +-10%25V XTR
C832	65G0805472 31	CHIP 4700PF 50V X7R 080
C833	65G0805104 22	0.1UF +-10% 25V X7R 080
C834	65G0805104 22	0.1UF +-10% 25V X7R 080
C835	65G0805105 22	CHIP 1UF 25V X7R 0805
C836	65G0805474 22	CHIP 0.47UF 25V X7R 080
C837	65G0805104 22	0.1UF +-10% 25V X7R 080
C838	65G0805104 22	0.1UF +-10% 25V X7R 080
C839	65G0805105 22	CHIP 1UF 25V X7R 0805
C848	65G0805104 22	0.1UF +-10% 25V X7R 080
C907	65G0805104 22	0.1UF +-10% 25V X7R 080
C910	65G0805104 22	0.1UF +-10% 25V X7R 080
C912	65G0805334 22	0.33UF+-10% 25V X7R 080
C914	65G0805104 22	0.1UF +-10% 25V X7R 080
C917	65G0805103 22	CHIP 0.01uF 25V X7R 080
C918	65G0805104 22	0.1UF +-10% 25V X7R 080
C919	65G0805221 21	220PF 25V 5%
C931	65G1206102 72	CHIP 1000PF 500V X7R
C932	65G1206102 72	CHIP 1000PF 500V X7R
C934	65G0805104 22	0.1UF +-10% 25V X7R 080
D801	93G 6433P	BAV99
D802	93G 6433P	BAV99
D806	93G 6433P	BAV99
D809	93G 6432V	LL4148-GS08
IC801	56G 608 7	OZT1060GN SOIC-20
IC901	56G 379 52	LD7552BS
J903	61L1206000	RST SM 1206 JUMP MAX 0R
J926	61L1206000	RST SM 1206 JUMP MAX 0R
JR901	61L1206000	RST SM 1206 JUMP MAX 0R
Q801	57G 417 4	PMBS3904/PHILIPS-SMT(04
Q806	57G 760 4	DTA144WKA BY ROHM SMT
Q807	57G 760 5	DTC144WKA BY ROHM SMT
Q808	57G 60040A	AM4512C-T1-PF SO-8
Q809	57G 60040A	AM4512C-T1-PF SO-8
Q812	57G 417 4	PMBS3904/PHILIPS-SMT(04

R801	61L0805682	CHIP 6.8KOHM 5% 0805 1/
R802	61L0805134	CHIP 130KOHM+-5% 1/8W
R803	61L0805471	CHIPR 470 OHM+-5% 1/8W
R804	61L0805681	680 OHM 1/10W
R805	61L0805102	CHIPR 1K OHM +-5% 1/8W
R806	61L0805681	680 OHM 1/10W
R808	61L0805393	SMD 39KOHM/0805/+5% 1/
R811	61L0805513	CHIP 51KOHM 1/8W
R812	61L0805333	CHIP 33KOHM 1% 1/8W
R813	61L0805513	CHIP 51KOHM 1/8W
R814	61L0805513	CHIP 51KOHM 1/8W
R819	61L0805220	CHIP 22 OHM 5% 0805 1/8
R820	61L0805220	CHIP 22 OHM 5% 0805 1/8
R824	61L0805103	CHIPR 10K OHM +-5% 1/8W
R825	61L0805683	CHIPR 68K OHM+-5% 1/8W
R828	61L0805103	CHIPR 10K OHM +-5% 1/8W
R829	61L1206100	CHIPR 10 OHM+-5% 1/4W
R830	61L0805753	75K 1/8W
R832	61L0805103	CHIPR 10K OHM +-5% 1/8W
R833	61L0805204	200K OHM 1/8W
R835	61L0805105	CHIP 1M OHM 5% 1/8W
R836	61L0805204	200K OHM 1/8W
R837	61L0805102	CHIPR 1K OHM +-5% 1/8W
R838	61L1206471	CHIPR 470 OHM+-5% 1/4W
R840	61L0805104	CHIPR 100K OHM+-5% 1/8W
R841	61L0805362	CHIP 306KOHM 1/8W
R842	61L0805104	CHIPR 100K OHM+-5% 1/8W
R843	61L0805472	CHIPR 4.7K OHM +-5% 1/8
R844	61L0805105	CHIP 1M OHM 5% 1/8W
R901	61L1206684	CHIPR 680K OHM+-5% 1/4W
R902	61L1206684	CHIPR 680K OHM+-5% 1/4W
R903	61L1206684	CHIPR 680K OHM+-5% 1/4W
R906	61L1206101	CHIP 100 OHM 5% 1/4W
R907	61L1206514	CHIPR 510KOHM +-5% 1/4W
R908	61L1206514	CHIPR 510KOHM +-5% 1/4W
R909	61L1206434	430K 1206 1/4W 5%
R910	61L1206434	430K 1206 1/4W 5%

R911	61L0805151	CHIP ISO HM 5% 1/8W
R912	61L0805750 2F	CHIP 75KOHM 1% 1/8W
R913	61L0805100 3F	CHIP 100KOHM +-1% 1/8W
R914	61L1206339	CHIP 3.3OHM 1/4W
R916	61L1206101	CHIP 100 OHM 5% 1/4W
R918	61L1206100	CHIPR 10 OHM+-5% 1/4W
R919	61L0805103	CHIPR 10K OHM +-5% 1/8W
R920	61L0805333	CHIP 33KOHM 1% 1/8W
R921	61L0805362	CHIP 306KOHM 1/8W
R922	61L0805242	CHIP 2.4KOHM 1% 1/8W
R923	61L0805102	CHIPR 1K OHM +-5% 1/8W
R924	61L0805102	CHIPR 1K OHM +-5% 1/8W
R925	61L0805202	CHIP 2KOHM 1/8W
R926	61L0805102	CHIPR 1K OHM +-5% 1/8W
R927	61L1206470	CHIP 47OHM 5% 1/4W
R928	61L0805331	CHIP 330 OHM 5% 1/10W
R930	61L0805100 3F	CHIP 100KOHM +-1% 1/8W
R931	61L1206434	430K 1206 1/4W 5%
R932	61L1206514	CHIPR 510KOHM +-5% 1/4W
R934	61L1206101	CHIP 100 OHM 5% 1/4W
R935	61L1206101	CHIP 100 OHM 5% 1/4W
R936	61L1206101	CHIP 100 OHM 5% 1/4W
R937	61L1206101	CHIP 100 OHM 5% 1/4W
ZD801	93G 39S 24 T	RLZ 5.6B LLDS
ZD802	93G 39S 24 T	RLZ 5.6B LLDS
ZD805	93G 39S 24 T	RLZ 5.6B LLDS
ZD902	93G 39S 17 T	RLZ12B LLDS
ZD903	93G 39S 19 T	PTZ7.5B
ZD904	93G 39S 25 T	RLZ5.1B LLDS
	715G1508 1	PWPC BOARD PCB
C905	6G 31502	1.5MM RIVET
C930	65G 1K152 1T6921	1.5nF/1K Y5P +-10%
CN901	6G 31500	EYELET
F901	84G 56 1	FUSE 2A 250V WICKMANN
IC903	56G 158 10 T	AZ431AZ-AE1
IC904	56G 158 10 T	AZ431AZ-AE1
L901	6G 31502	1.5MM RIVET

NR901	6G 31502	1.5MM RIVET
PT801	6G 31502	1.5MM RIVET
R823	61L212Y625 KT	6.2M 3KV KAMAYA
T901	6G 31502	1.5MM RIVET
	M1G1730 8128	SCREW M3x8
HS1	90G6064 1	HEAT SINK
Q903	57G 667 30	2SK2645
	M1G1730 8128	SCREW M3x8
D902	93G 60252	SP20150
HS2	90G6084 1 GP	HEAT SINK
	M1G1730 8128	SCREW M3x8
D904	93G 60248	SP20100
ZD3	90G6084 1 GP	HEAT SINK
R905	61G152M10458F	100K OHM 5% 2W
R905	96G 29 6	SHRINK TUBE UL/CSA
	34FPE19P03	CASE EEL19
	87G 501 14 RF	AC SOCKET
	95G8021 5500	HARNESS
	96G 29 6	SHRINK TUBE UL/CSA
	33G4857APM L	CONTROL BUTTON
	33G4858APM L	POWER BUTTON
	33G4859 1 C	LENS
	34G1562APC B	BEZEL
	15G8161 1	BASE BRACKET
	34G1566 EY B	BASE
	34G1625 EY B	STAND
	37G 513 4	HINGE
	Q1G 130 6120	SCREW (T3X6)
	Q1G 140 8128	SCREW