

SN74LVC1G373 Single D-Type Latch With 3-State Output

1 Features

- Available in the Texas Instruments NanoFree™ Package
- Supports 5-V V_{CC} Operation
- Inputs Accept Voltages to 5.5 V
- Provides Down Translation to V_{CC}
- Max t_{pd} of 4 ns at 3.3 V
- Low Power Consumption: 10- μ A Maximum I_{CC}
- ± 24 -mA Output Drive at 3.3 V
- I_{off} Supports Live Insertion, Partial-Power-Down Mode, and Back Drive Protection
- Latch-Up Performance Exceeds 100 mA Per JESD 78, Class II

2 Applications

- Servers
- Printers
- Telecom and Grid Infrastructure
- Memory Addressing
- Buffer Registers
- Electronic Point of Sale

3 Description

The SN74LVC1G373 device is a single D-type latch designed for 1.65-V to 5.5-V V_{CC} operation.

This device is particularly suitable for implementing buffer registers, I/O ports, bidirectional bus drivers, and working registers. While the latch-enable (LE) input is high, the Q outputs follow the data (D) inputs. When LE is taken low, the Q outputs are latched at the logic levels set up at the D inputs.

NanoFree™ package technology is a major breakthrough in IC packaging concepts, using the die as the package.

\overline{OE} does not affect the internal operations of the latch. Old data can be retained or new data can be entered while the outputs are in the high-impedance state.

Device Information(1)

PACKAGE NUMBER	PACKAGE	BODY SIZE (NOM)
SN74LVC1G373DBV	SOT-23 (6)	2.90 mm x 1.60 mm
SN74LVC1G373DCK	SC70 (6)	2.00 mm x 1.25 mm
SN74LVC1G373YZP	DSBGA (6)	1.41 mm x 0.91 mm

(1) For all available packages, see the orderable addendum at the end of the data sheet.

Logic Diagram (Positive Logic)

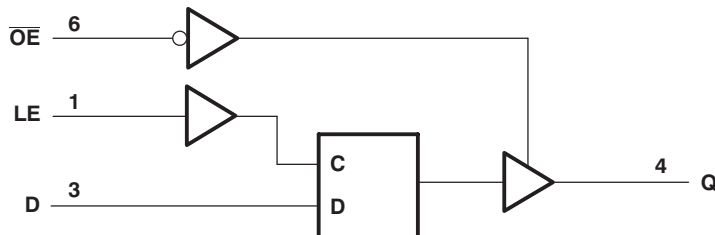

Table of Contents

1 Features	1	8 Detailed Description	12
2 Applications	1	8.1 Overview	12
3 Description	1	8.2 Functional Block Diagram	12
4 Revision History	2	8.3 Feature Description	12
5 Pin Configuration and Functions	3	8.4 Device Functional Modes	12
6 Specifications	4	9 Application and Implementation	13
6.1 Absolute Maximum Ratings	4	9.1 Application Information	13
6.2 ESD Ratings	4	9.2 Typical Application	13
6.3 Recommended Operating Conditions	5	10 Power Supply Recommendations	15
6.4 Thermal Information	5	11 Layout	15
6.5 Electrical Characteristics	6	11.1 Layout Guidelines	15
6.6 Timing Requirements: $T_A = -40^{\circ}\text{C}$ to 85°C	6	11.2 Layout Example	15
6.7 Timing Requirements: $T_A = -40^{\circ}\text{C}$ to 125°C	6	12 Device and Documentation Support	16
6.8 Switching Characteristics: $T_A = -40^{\circ}\text{C}$ to 85°C	7	12.1 Receiving Notification of Documentation Updates	16
6.9 Switching Characteristics: $T_A = -40^{\circ}\text{C}$ to 85°C	7	12.2 Community Resource	16
6.10 Switching Characteristics: $T_A = -40^{\circ}\text{C}$ to 125°C	8	12.3 Trademarks	16
6.11 Operating Characteristics	8	12.4 Electrostatic Discharge Caution	16
6.12 Typical Characteristics	9	12.5 Glossary	16
7 Parameter Measurement Information	10	13 Mechanical, Packaging, and Orderable Information	16

4 Revision History

NOTE: Page numbers for previous revisions may differ from page numbers in the current version.

Changes from Revision D (December 2013) to Revision E	Page
<ul style="list-style-type: none"> Added <i>Applications</i> section, <i>Device Information</i> table, <i>ESD Ratings</i> table, <i>Feature Description</i> section, <i>Device Functional Modes</i>, <i>Application and Implementation</i> section, <i>Power Supply Recommendations</i> section, <i>Layout</i> section, <i>Device and Documentation Support</i> section, and <i>Mechanical, Packaging, and Orderable Information</i> section 	1

Changes from Revision C (May 2007) to Revision D	Page
<ul style="list-style-type: none"> Updated document to new TI data sheet format 	1
<ul style="list-style-type: none"> Deleted Ordering Information table; see POA at the end of the data sheet 	1
<ul style="list-style-type: none"> Updated operating temperature range 	5

5 Pin Configuration and Functions

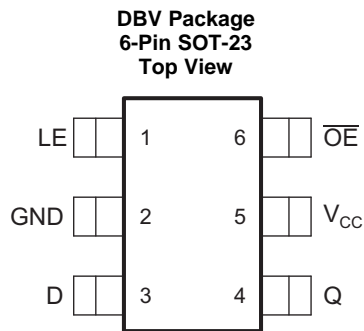

See mechanical drawings for dimensions.

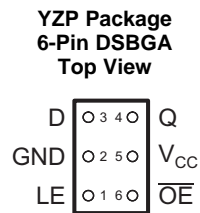
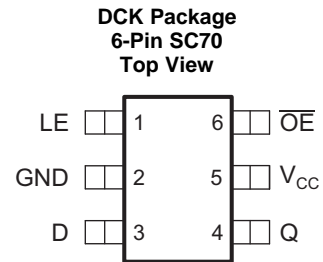

Pin Functions

PIN		I/O	DESCRIPTION
NO.	NAME		
1	LE	I	Latch Enable; output follows D input when high
2	GND	—	Ground
3	D	I	D latch input
4	Q	O	Q latch output
5	V _{CC}	—	Power pin
6	$\overline{\text{OE}}$	I	Active Low Output Enable; Hi-Z output when high

6 Specifications

6.1 Absolute Maximum Ratings

over operating free-air temperature range (unless otherwise noted)⁽¹⁾

		MIN	MAX	UNIT
V _{CC}	Supply voltage	–0.5	6.5	V
V _I	Input voltage ⁽²⁾	–0.5	6.5	V
V _O	Voltage range applied to any output in the high-impedance or power-off state ⁽²⁾⁽³⁾	–0.5	6.5	V
V _O	Voltage range applied to any output in the high or low state ⁽²⁾⁽³⁾	–0.5	V _{CC} + 0.5	V
I _{IK}	Input clamp current	V _I < 0	–50	mA
I _{OK}	Output clamp current	V _O < 0	–50	mA
I _O	Continuous output current		±50	mA
	Continuous current through V _{CC} or GND		±100	mA
T _J	Absolute maximum Junction temperature		150	°C
T _{stg}	Storage temperature	–65	150	°C

- (1) Stresses beyond those listed under *Absolute Maximum Ratings* may cause permanent damage to the device. These are stress ratings only, which do not imply functional operation of the device at these or any other conditions beyond those indicated under *Recommended Operating Conditions*. Exposure to absolute-maximum-rated conditions for extended periods may affect device reliability.
- (2) The input and output negative-voltage ratings may be exceeded if the input and output current ratings are observed.
- (3) The value of V_{CC} is provided in the *Recommended Operating Conditions*.

6.2 ESD Ratings

		VALUE	UNIT
V _(ESD)	Electrostatic discharge	Human-body model (HBM), per ANSI/ESDA/JEDEC JS-001 ⁽¹⁾	V
		Charged-device model (CDM), per JEDEC specification JESD22-C101 ⁽²⁾	

- (1) JEDEC document JEP155 states that 500-V HBM allows safe manufacturing with a standard ESD control process.
- (2) JEDEC document JEP157 states that 250-V CDM allows safe manufacturing with a standard ESD control process. CDM tested on DBV package

6.3 Recommended Operating Conditions

See ⁽¹⁾

			MIN	MAX	UNIT
V _{CC}	Supply voltage	Operating	1.65	5.5	V
		Data retention only	1.5		
V _{IH}	High-level input voltage	V _{CC} = 1.65 V to 1.95 V	0.65 × V _{CC}	5.5	V
		V _{CC} = 2.3 V to 2.7 V	1.7	5.5	
		V _{CC} = 3 V to 3.6 V	2	5.5	
		V _{CC} = 4.5 V to 5.5 V	0.7 × V _{CC}	5.5	
V _{IL}	Low-level input voltage	V _{CC} = 1.65 V to 1.95 V	0	0.35 × V _{CC}	V
		V _{CC} = 2.3 V to 2.7 V	0	0.7	
		V _{CC} = 3 V to 3.6 V	0	0.8	
		V _{CC} = 4.5 V to 5.5 V	0	0.3 × V _{CC}	
V _O	Output voltage		0	V _{CC}	V
I _{OH}	High-level output current	V _{CC} = 1.65 V		-4	mA
		V _{CC} = 2.3 V		-8	
		V _{CC} = 3 V		-16	
		V _{CC} = 4.5 V		-24	
I _{OL}	Low-level output current	V _{CC} = 1.65 V		4	mA
		V _{CC} = 2.3 V		8	
		V _{CC} = 3 V		16	
		V _{CC} = 4.5 V		24	
Δt/Δv	Input transition rise or fall rate	V _{CC} = 1.8 V ± 0.15 V, 2.5 V ± 0.2 V		20	ns/V
		V _{CC} = 3.3 V ± 0.3 V		10	
		V _{CC} = 5 V ± 0.5 V		5	
T _A	Operating free-air temperature	DSBGA package	-40	85	°C
		All other packages	-40	125	

(1) All unused inputs of the device must be held at V_{CC} or GND to ensure proper device operation. See the TI application report, [Implications of Slow or Floating CMOS Inputs](#) (SCBA004).

6.4 Thermal Information

THERMAL METRIC ⁽¹⁾		SN74LVC1G373			UNIT
		DBV (SOT-23)	DCK (SC70)	YZP (DSBGA)	
		6 PINS	6 PINS	6 PINS	
R _{θJA}	Junction-to-ambient thermal resistance	219.8	255.2	131	°C/W
R _{θJC(top)}	Junction-to-case (top) thermal resistance	189	121.9	1.3	°C/W
R _{θJB}	Junction-to-board thermal resistance	65.8	58	22.6	°C/W
ψ _{JT}	Junction-to-top characterization parameter	67.3	7.2	5.2	°C/W
ψ _{JB}	Junction-to-board characterization parameter	65.2	57.3	22.6	°C/W

(1) For more information about traditional and new thermal metrics, see the [Semiconductor and IC Package Thermal Metrics](#) application report.

6.5 Electrical Characteristics

over recommended operating free-air temperature range (unless otherwise noted)

PARAMETER	TEST CONDITIONS	V _{CC}	MIN	TYP ⁽¹⁾	MAX	UNIT	
V _{OH}	I _{OH} = -100 μA	1.65 V to 5.5 V	V _{CC} - 0.1			V	
	I _{OH} = -4 mA	1.65 V	1.2				
	I _{OH} = -8 mA	2.3 V	1.9				
	I _{OH} = -16 mA	3 V	2.4				
	I _{OH} = -24 mA		2.3				
	I _{OH} = -32 mA	4.5 V	3.8				
V _{OL}	I _{OL} = 100 μA	1.65 V to 5.5 V			0.1	V	
	I _{OL} = 4 mA	1.65 V			0.45		
	I _{OL} = 8 mA	2.3 V			0.3		
	I _{OL} = 16 mA	3 V			0.4		
	I _{OL} = 24 mA		T _A = -40°C to 85°C				0.55
			T _A = -40°C to 125°C				0.65
	I _{OL} = 32 mA	T _A = -40°C to 85°C	4.5 V				0.55
		T _A = -40°C to 125°C					0.65
I _I	V _I = 5.5 V or GND	0 V to 5.5 V			±1	μA	
I _{OZ}	V _O = 0 to 5.5 V	3.6 V			±5		
I _{off}	V _I or V _O = 5.5 V	0			±10		
I _{CC}	V _I = 5.5 V or GND, I _O = 0	1.65 V to 5.5 V			10		
ΔI _{CC}	One input at V _{CC} - 0.6 V, Other inputs at V _{CC} or GND	3 V to 5.5 V			500		
C _i	V _I = V _{CC} or GND	T _A = -40°C to 85°C	3.3 V		3.5	pF	
C _o	V _O = V _{CC} or GND	T _A = -40°C to 85°C	3.3 V		6		

 (1) All typical values are at V_{CC} = 3.3 V, T_A = 25°C.

6.6 Timing Requirements: T_A = -40°C to 85°C

 over recommended operating free-air temperature range (unless otherwise noted) (see [Figure 2](#))

		MIN	MAX	UNIT
t _w	Pulse duration, LE high	3		ns
t _{su}	Setup time, data before LE↓	V _{CC} = 1.8 V ± 0.15 V	2.4	
		V _{CC} = 2.5 V ± 0.2 V	2	
		V _{CC} = 3.3 V ± 0.3 V	1.5	
		V _{CC} = 5 V ± 0.5 V	1.5	
t _h	Hold time, data after LE↓	V _{CC} = 1.8 V ± 0.15 V	2.5	
		V _{CC} = 2.5 V ± 0.2 V	1.5	
		V _{CC} = 3.3 V ± 0.3 V	1.5	
		V _{CC} = 5 V ± 0.5 V	1.5	

6.7 Timing Requirements: T_A = -40°C to 125°C

 over recommended operating free-air temperature range (unless otherwise noted) (see [Figure 2](#))

		MIN	MAX	UNIT
t _w	Pulse duration, LE high	3		ns
t _{su}	Setup time, data before LE↓	V _{CC} = 1.8 V ± 0.15 V	2.9	
		V _{CC} = 2.5 V ± 0.2 V	2.1	
		V _{CC} = 3.3 V ± 0.3 V	1.5	
		V _{CC} = 5 V ± 0.5 V	1.5	
t _h	Hold time, data after LE↓	V _{CC} = 1.8 V ± 0.15 V	3	
		V _{CC} = 2.5 V ± 0.2 V	1.5	
		V _{CC} = 3.3 V ± 0.3 V	1.5	
		V _{CC} = 5 V ± 0.5 V	1.5	

6.8 Switching Characteristics: $T_A = -40^{\circ}\text{C}$ to 85°C

 over recommended operating free-air temperature range, $C_L = 15\text{ pF}$ (unless otherwise noted) (see [Figure 2](#))

PARAMETER	FROM (INPUT)	TO (OUTPUT)	TEST CONDITIONS	MIN	MAX	UNIT
t_{pd}	D	Q	$V_{CC} = 1.8\text{ V} \pm 0.15\text{ V}$	2	15	ns
			$V_{CC} = 2.5\text{ V} \pm 0.2\text{ V}$	15	5	
			$V_{CC} = 3.3\text{ V} \pm 0.3\text{ V}$	1	4	
			$V_{CC} = 5\text{ V} \pm 0.5\text{ V}$	1	3.5	
	LE		$V_{CC} = 1.8\text{ V} \pm 0.15\text{ V}$	2	15	
			$V_{CC} = 2.5\text{ V} \pm 0.2\text{ V}$	1.5	5	
			$V_{CC} = 3.3\text{ V} \pm 0.3\text{ V}$	1	4	
			$V_{CC} = 5\text{ V} \pm 0.5\text{ V}$	1	3.5	
t_{en}	\overline{OE}	Q	$V_{CC} = 1.8\text{ V} \pm 0.15\text{ V}$	2	12.5	
			$V_{CC} = 2.5\text{ V} \pm 0.2\text{ V}$	1.5	4.5	
			$V_{CC} = 3.3\text{ V} \pm 0.3\text{ V}$	1	4	
			$V_{CC} = 5\text{ V} \pm 0.5\text{ V}$	1	2.5	
t_{dis}	\overline{OE}	Q	$V_{CC} = 1.8\text{ V} \pm 0.15\text{ V}$	2	14	
			$V_{CC} = 2.5\text{ V} \pm 0.2\text{ V}$	1.5	7	
			$V_{CC} = 3.3\text{ V} \pm 0.3\text{ V}$	1	7.9	
			$V_{CC} = 5\text{ V} \pm 0.5\text{ V}$	1	5.3	

6.9 Switching Characteristics: $T_A = -40^{\circ}\text{C}$ to 85°C

 over recommended operating free-air temperature range, $C_L = 30\text{ pF}$ or 50 pF (unless otherwise noted) (see [Figure 3](#))

PARAMETER	FROM (INPUT)	TO (OUTPUT)	TEST CONDITIONS	MIN	MAX	UNIT
t_{pd}	D	Q	$V_{CC} = 1.8\text{ V} \pm 0.15\text{ V}$	2	16	ns
			$V_{CC} = 2.5\text{ V} \pm 0.2\text{ V}$	1.5	7.3	
			$V_{CC} = 3.3\text{ V} \pm 0.3\text{ V}$	1	5.4	
			$V_{CC} = 5\text{ V} \pm 0.5\text{ V}$	1	4	
	LE		$V_{CC} = 1.8\text{ V} \pm 0.15\text{ V}$	2	16.3	
			$V_{CC} = 2.5\text{ V} \pm 0.2\text{ V}$	1.5	7.4	
			$V_{CC} = 3.3\text{ V} \pm 0.3\text{ V}$	1	5.5	
			$V_{CC} = 5\text{ V} \pm 0.5\text{ V}$	1	4	
t_{en}	\overline{OE}	Q	$V_{CC} = 1.8\text{ V} \pm 0.15\text{ V}$	2	13	
			$V_{CC} = 2.5\text{ V} \pm 0.2\text{ V}$	1.5	6.3	
			$V_{CC} = 3.3\text{ V} \pm 0.3\text{ V}$	1	5.1	
			$V_{CC} = 5\text{ V} \pm 0.5\text{ V}$	1	3.7	
t_{dis}	\overline{OE}	Q	$V_{CC} = 1.8\text{ V} \pm 0.15\text{ V}$	2	17.4	
			$V_{CC} = 2.5\text{ V} \pm 0.2\text{ V}$	1	5.9	
			$V_{CC} = 3.3\text{ V} \pm 0.3\text{ V}$	1	6.5	
			$V_{CC} = 5\text{ V} \pm 0.5\text{ V}$	1	4.6	

6.10 Switching Characteristics: $T_A = -40^\circ\text{C}$ to 125°C

 over recommended operating free-air temperature range, $C_L = 30\text{ pF}$ or 50 pF (unless otherwise noted) (see [Figure 3](#))

PARAMETER	FROM (INPUT)	TO (OUTPUT)	TEST CONDITIONS	MIN	MAX	UNIT
t_{pd}	D	Q	$V_{CC} = 1.8\text{ V} \pm 0.15\text{ V}$	2	17	ns
			$V_{CC} = 2.5\text{ V} \pm 0.2\text{ V}$	1.5	8	
			$V_{CC} = 3.3\text{ V} \pm 0.3\text{ V}$	1	6	
			$V_{CC} = 5\text{ V} \pm 0.5\text{ V}$	1	4.5	
	LE		$V_{CC} = 1.8\text{ V} \pm 0.15\text{ V}$	2	17	
			$V_{CC} = 2.5\text{ V} \pm 0.2\text{ V}$	1.5	8	
			$V_{CC} = 3.3\text{ V} \pm 0.3\text{ V}$	1	6	
			$V_{CC} = 5\text{ V} \pm 0.5\text{ V}$	1	4.5	
t_{en}	\overline{OE}	Q	$V_{CC} = 1.8\text{ V} \pm 0.15\text{ V}$	2	13.5	
			$V_{CC} = 2.5\text{ V} \pm 0.2\text{ V}$	1.5	7	
			$V_{CC} = 3.3\text{ V} \pm 0.3\text{ V}$	1	5.5	
			$V_{CC} = 5\text{ V} \pm 0.5\text{ V}$	1	4	
t_{dis}	\overline{OE}	Q	$V_{CC} = 1.8\text{ V} \pm 0.15\text{ V}$	2	18.4	
			$V_{CC} = 2.5\text{ V} \pm 0.2\text{ V}$	1	6.2	
			$V_{CC} = 3.3\text{ V} \pm 0.3\text{ V}$	1	6.8	
			$V_{CC} = 5\text{ V} \pm 0.5\text{ V}$	1	5	
t_{en}	\overline{OE}	Q	$V_{CC} = 1.8\text{ V} \pm 0.15\text{ V}$	2	14	
			$V_{CC} = 2.5\text{ V} \pm 0.2\text{ V}$	1.5	8.3	
			$V_{CC} = 3.3\text{ V} \pm 0.3\text{ V}$	0.9	6.5	
			$V_{CC} = 5\text{ V} \pm 0.5\text{ V}$	0.7	5.5	
t_{dis}	\overline{OE}	Q	$V_{CC} = 1.8\text{ V} \pm 0.15\text{ V}$	2	16	
			$V_{CC} = 2.5\text{ V} \pm 0.2\text{ V}$	1.1	7.3	
			$V_{CC} = 3.3\text{ V} \pm 0.3\text{ V}$	1.4	6	
			$V_{CC} = 5\text{ V} \pm 0.5\text{ V}$	0.8	5.1	

6.11 Operating Characteristics

 $T_A = 25^\circ\text{C}$

PARAMETER		TEST CONDITIONS	TYP	UNIT	
C_{pd}	Power dissipation capacitance	$f = 10\text{ MHz}$	$V_{CC} = 1.8\text{ V}$	19	pF
			$V_{CC} = 2.5\text{ V}$	19	
			$V_{CC} = 3.3\text{ V}$	19	
			$V_{CC} = 5\text{ V}$	20	
			$V_{CC} = 1.8\text{ V}$	3	
			$V_{CC} = 2.5\text{ V}$	3	
			$V_{CC} = 3.3\text{ V}$	3	
			$V_{CC} = 5\text{ V}$	4	

6.12 Typical Characteristics

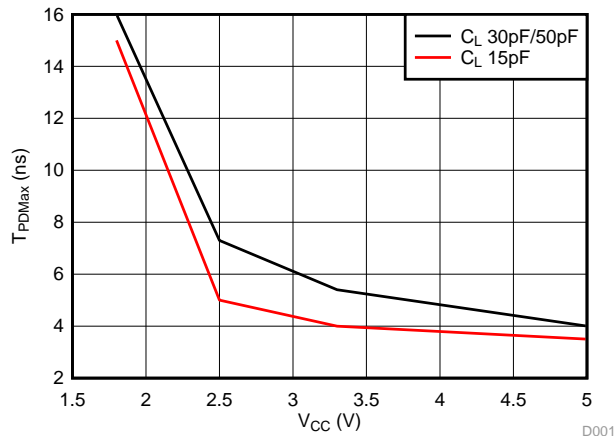
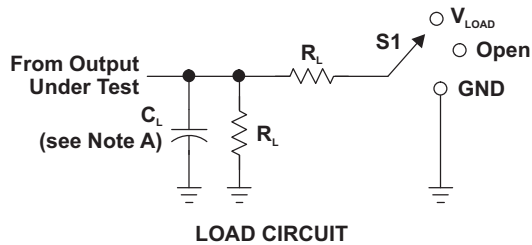

Figure 1. Propagation delay vs V_{CC}

7 Parameter Measurement Information



TEST	S1
t_{PLH}/t_{PHL}	Open
t_{PLZ}/t_{PZL}	V_{LOAD}
t_{PHZ}/t_{PZH}	GND

V_{CC}	INPUTS		V_M	V_{LOAD}	C_L	R_L	V_{Δ}
	V_i	t_i/t_r					
$1.8\text{ V} \pm 0.15\text{ V}$	V_{CC}	$\leq 2\text{ ns}$	$V_{CC}/2$	$2 \times V_{CC}$	15 pF	1 M Ω	0.15 V
$2.5\text{ V} \pm 0.2\text{ V}$	V_{CC}	$\leq 2\text{ ns}$	$V_{CC}/2$	$2 \times V_{CC}$	15 pF	1 M Ω	0.15 V
$3.3\text{ V} \pm 0.3\text{ V}$	3 V	$\leq 2.5\text{ ns}$	1.5 V	6 V	15 pF	1 M Ω	0.3 V
$5\text{ V} \pm 0.5\text{ V}$	V_{CC}	$\leq 2.5\text{ ns}$	$V_{CC}/2$	$2 \times V_{CC}$	15 pF	1 M Ω	0.3 V

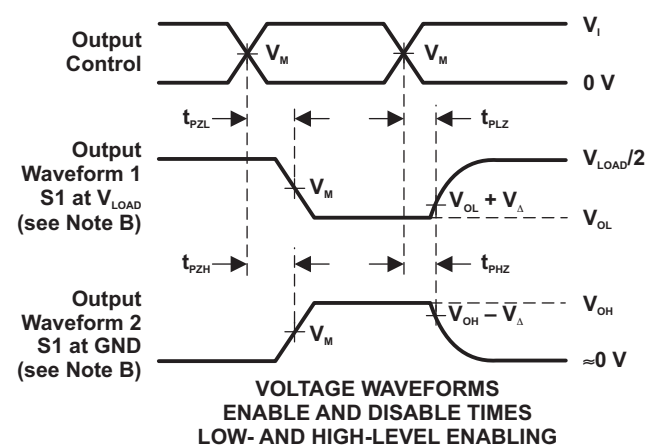
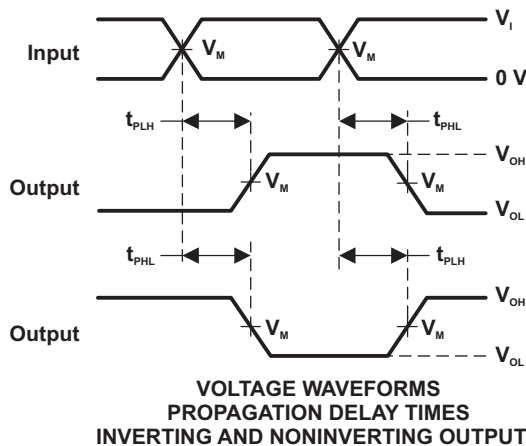
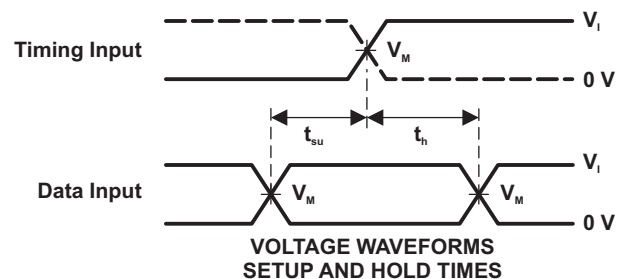
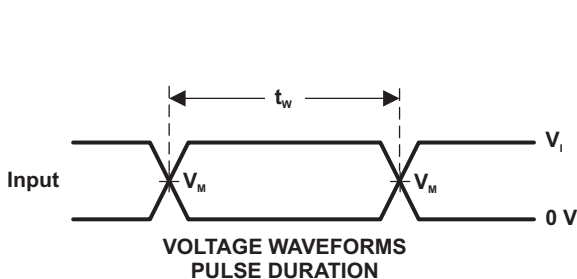

- NOTES: A. C_L includes probe and jig capacitance.
 B. Waveform 1 is for an output with internal conditions such that the output is low, except when disabled by the output control. Waveform 2 is for an output with internal conditions such that the output is high, except when disabled by the output control.
 C. All input pulses are supplied by generators having the following characteristics: PRR \leq 10 MHz, $Z_o = 50\ \Omega$.
 D. The outputs are measured one at a time, with one transition per measurement.
 E. t_{PLZ} and t_{PHZ} are the same as t_{dis} .
 F. t_{PZL} and t_{PZH} are the same as t_{en} .
 G. t_{PLH} and t_{PHL} are the same as t_{pd} .
 H. All parameters and waveforms are not applicable to all devices.

Figure 2. Load Circuit and Voltage Waveforms

Parameter Measurement Information (continued)

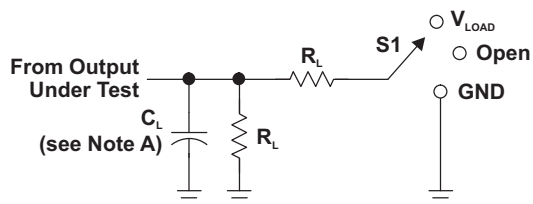

LOAD CIRCUIT

TEST	S1
t_{PLH}/t_{PHL}	Open
t_{PLZ}/t_{PZL}	V_{LOAD}
t_{PHZ}/t_{PZH}	GND

V_{CC}	INPUTS		V_M	V_{LOAD}	C_L	R_L	V_{Δ}
	V_I	t_f/t_r					
$1.8 V \pm 0.15 V$	V_{CC}	$\leq 2 ns$	$V_{CC}/2$	$2 \times V_{CC}$	30 pF	1 k Ω	0.15 V
$2.5 V \pm 0.2 V$	V_{CC}	$\leq 2 ns$	$V_{CC}/2$	$2 \times V_{CC}$	30 pF	500 Ω	0.15 V
$3.3 V \pm 0.3 V$	3 V	$\leq 2.5 ns$	1.5 V	6 V	50 pF	500 Ω	0.3 V
$5 V \pm 0.5 V$	V_{CC}	$\leq 2.5 ns$	$V_{CC}/2$	$2 \times V_{CC}$	50 pF	500 Ω	0.3 V

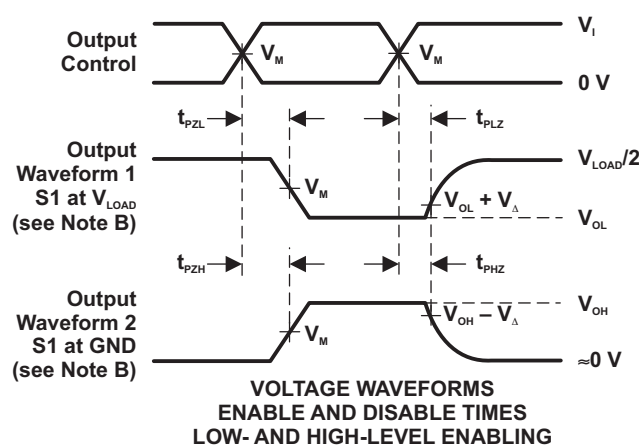
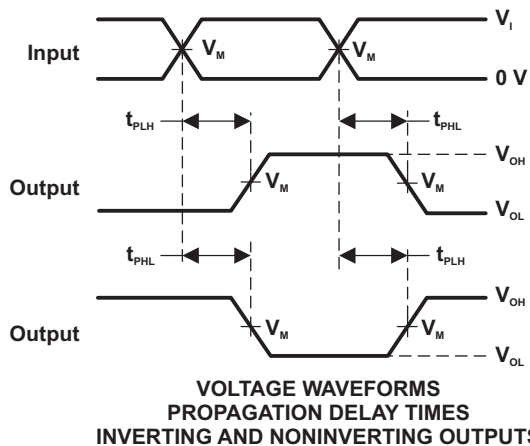
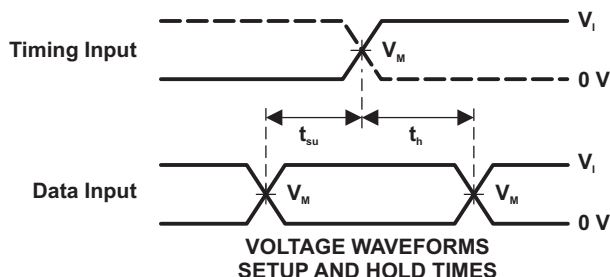
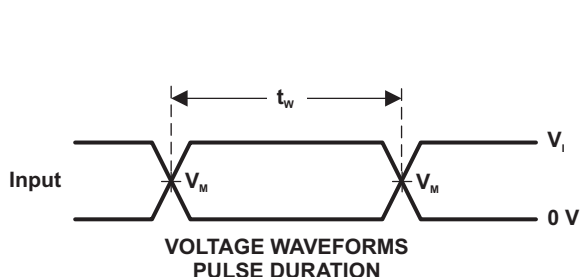

- NOTES: A. C_L includes probe and jig capacitance.
 B. Waveform 1 is for an output with internal conditions such that the output is low, except when disabled by the output control. Waveform 2 is for an output with internal conditions such that the output is high, except when disabled by the output control.
 C. All input pulses are supplied by generators having the following characteristics: PRR \leq 10 MHz, $Z_o = 50 \Omega$.
 D. The outputs are measured one at a time, with one transition per measurement.
 E. t_{PLZ} and t_{PHZ} are the same as t_{dis} .
 F. t_{PZL} and t_{PZH} are the same as t_{on} .
 G. t_{PLH} and t_{PHL} are the same as t_{pd} .
 H. All parameters and waveforms are not applicable to all devices.

Figure 3. Load Circuit and Voltage Waveforms

8 Detailed Description

8.1 Overview

A buffered output-enable (\overline{OE}) input can be used to place the output in either a normal logic state (high or low logic levels) or the high-impedance state. In the high-impedance state, the output neither loads nor drives the bus lines significantly. The high-impedance state and increased drive provide the capability to drive bus lines without interface or pullup components. To ensure the high-impedance state during power up or power down, \overline{OE} should be tied to V_{CC} through a pullup resistor; the minimum value of the resistor is determined by the current-sinking capability of the driver. This device is fully specified for partial-power-down applications using I_{off} . The I_{off} circuitry disables the outputs, preventing damaging current backflow through the device when it is powered down.

8.2 Functional Block Diagram

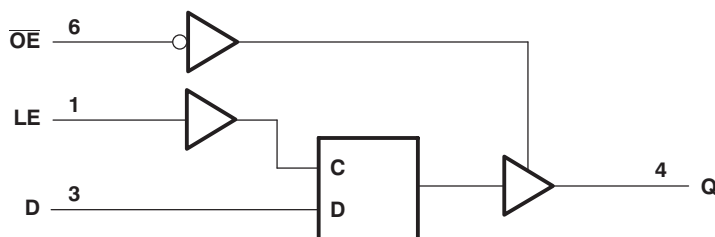

Figure 4. Logic Diagram (Positive Logic)

8.3 Feature Description

The SN74LVC1G373 supports 5-V V_{CC} operation and the input is over voltage tolerant up to 5.5 V providing down translation to V_{CC} . The device has low power consumption of 10- μ A max I_{CC} across temperature along with maximum t_{pd} of 4 ns at 3.3 V. It provides ± 24 -mA output drive at 3.3-V V_{CC} and up to ± 32 mA at 5.5-V V_{CC} . The I_{off} circuitry supports live insertion, partial-power-down mode, and back drive protection.

8.4 Device Functional Modes

[Table 1](#) lists the functions of this device.

Table 1. Function Table

INPUTS			OUTPUT Q
\overline{OE}	LE	D	
L	H	L	L
L	H	H	H
L	L	X	Q_0
H	X	X	Hi-Z

9 Application and Implementation

NOTE

Information in the following applications sections is not part of the TI component specification, and TI does not warrant its accuracy or completeness. TI's customers are responsible for determining suitability of components for their purposes. Customers should validate and test their design implementation to confirm system functionality.

9.1 Application Information

The SN74LVC1G373 latches can be used to store one bit of data. Figure 5 shows a typical application. The multiplexer is used to convert parallel data coming in from the latch into serial data using the A, B, and C select pins moving up in a sequence. With latch input low by a trigger event, the output Q holds the previous Q_0 data entered until the LE pin is cleared.

9.2 Typical Application

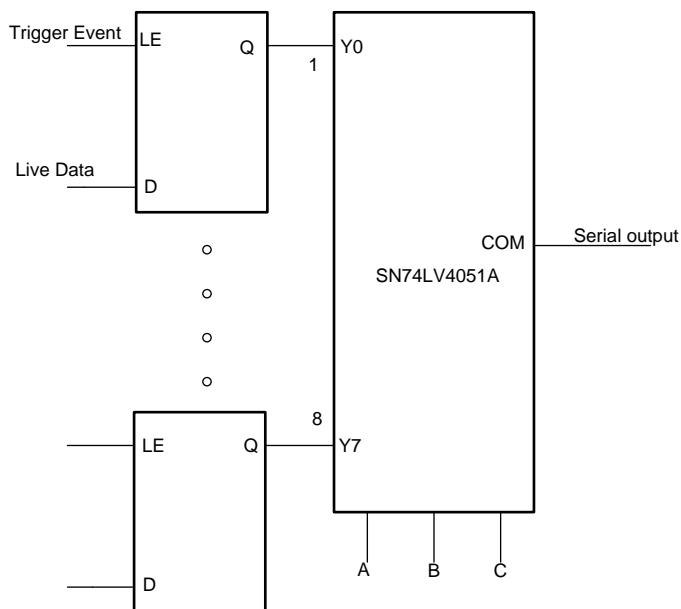

Copyright © 2016, Texas Instruments Incorporated

Figure 5. Latch Used With Multiplexer for Parallel to Serial Conversion

9.2.1 Design Requirements

This device uses CMOS technology and has balanced output drive. Take care to avoid bus contention because it can drive currents that would exceed maximum limits. The high drive also creates fast edges into light loads, so routing and load conditions must be considered to prevent ringing.

Typical Application (continued)

9.2.2 Detailed Design Procedure

1. Recommended Input Conditions
 - For rise time and fall time specifications, see $\Delta t/\Delta V$ in *Recommended Operating Conditions*.
 - For specified High and low levels, see V_{IH} and V_{IL} in *Recommended Operating Conditions*.
 - Inputs are overvoltage tolerant allowing them to go as high as 5.5 V at any valid V_{CC} .
2. Recommended Output Conditions
 - Load currents should not exceed 32 mA per output and 100 mA total through the part.
 - Outputs must not be pulled above V_{CC} .

9.2.3 Application Curve

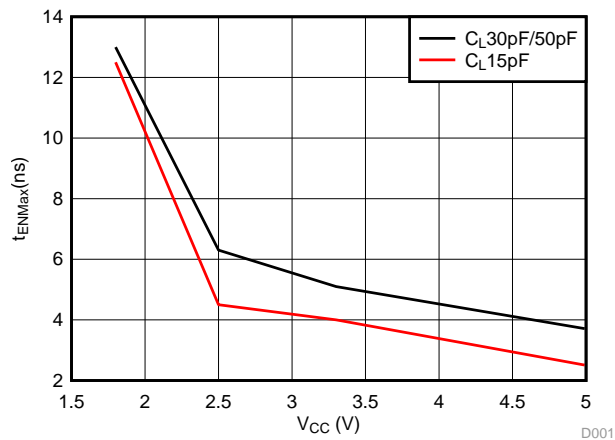

Figure 6. Enable Time vs V_{CC}

10 Power Supply Recommendations

The power supply can be any voltage between the minimum and maximum supply voltage rating located in [Recommended Operating Conditions](#).

Each V_{CC} pin should have a good bypass capacitor to prevent power disturbance. For devices with a single supply, TI recommends a 0.1- μF bypass capacitor. If there are multiple V_{CC} pins, TI recommends 0.01- μF or 0.022- μF bypass capacitor for each power pin. It is acceptable to parallel multiple bypass capacitors to reject different frequencies of noise. 0.1- μF and 1- μF capacitors are commonly used in parallel. The bypass capacitor should be installed as close to the power pin as possible for best results.

11 Layout

11.1 Layout Guidelines

When using multiple bit logic devices, inputs should not float. In many cases, functions or parts of functions of digital logic devices are unused. Some examples are when only two inputs of a triple-input AND gate are used, or when only 3 of the 4-buffer gates are used. Such input pins should not be left unconnected because the undefined voltages at the outside connections result in undefined operational states.

Specified in [Figure 7](#) are rules that must be observed under all circumstances. All unused inputs of digital logic devices must be connected to a high or low bias to prevent them from floating. The logic level that should be applied to any particular unused input depends on the function of the device. Generally they will be tied to GND or V_{CC} , whichever makes more sense or is more convenient. It is acceptable to float outputs unless the part is a transceiver. If the transceiver has an output enable pin, it will disable the outputs section of the part when asserted. This will not disable the input section of the I/Os so they also cannot float when disabled.

11.2 Layout Example

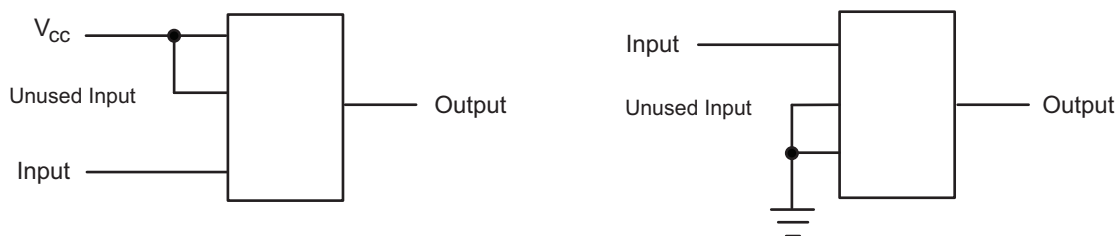

Figure 7. Layout Diagram

12 Device and Documentation Support

12.1 Receiving Notification of Documentation Updates

To receive notification of documentation updates, navigate to the device product folder on ti.com. In the upper right corner, click on *Alert me* to register and receive a weekly digest of any product information that has changed. For change details, review the revision history included in any revised document.

12.2 Community Resource

The following links connect to TI community resources. Linked contents are provided "AS IS" by the respective contributors. They do not constitute TI specifications and do not necessarily reflect TI's views; see TI's [Terms of Use](#).

TI E2E™ Online Community *TI's Engineer-to-Engineer (E2E) Community*. Created to foster collaboration among engineers. At e2e.ti.com, you can ask questions, share knowledge, explore ideas and help solve problems with fellow engineers.

Design Support *TI's Design Support* Quickly find helpful E2E forums along with design support tools and contact information for technical support.

12.3 Trademarks

NanoFree, E2E are trademarks of Texas Instruments.
All other trademarks are the property of their respective owners.

12.4 Electrostatic Discharge Caution



These devices have limited built-in ESD protection. The leads should be shorted together or the device placed in conductive foam during storage or handling to prevent electrostatic damage to the MOS gates.

12.5 Glossary

[SLYZ022](#) — *TI Glossary*.

This glossary lists and explains terms, acronyms, and definitions.

13 Mechanical, Packaging, and Orderable Information

The following pages include mechanical, packaging, and orderable information. This information is the most current data available for the designated devices. This data is subject to change without notice and revision of this document. For browser-based versions of this data sheet, refer to the left-hand navigation.

PACKAGING INFORMATION

Orderable Device	Status (1)	Package Type	Package Drawing	Pins	Package Qty	Eco Plan (2)	Lead/Ball Finish (6)	MSL Peak Temp (3)	Op Temp (°C)	Device Marking (4/5)	Samples
74LVC1G373DBVRE4	ACTIVE	SOT-23	DBV	6	3000	Green (RoHS & no Sb/Br)	CU NIPDAU	Level-1-260C-UNLIM	-40 to 125	(CA35 ~ CA3R)	Samples
74LVC1G373DCKRE4	ACTIVE	SC70	DCK	6	3000	Green (RoHS & no Sb/Br)	CU NIPDAU	Level-1-260C-UNLIM	-40 to 125	(D35 ~ D3R)	Samples
74LVC1G373DCKRG4	ACTIVE	SC70	DCK	6	3000	Green (RoHS & no Sb/Br)	CU NIPDAU	Level-1-260C-UNLIM	-40 to 125	(D35 ~ D3R)	Samples
SN74LVC1G373DBVR	ACTIVE	SOT-23	DBV	6	3000	Green (RoHS & no Sb/Br)	CU NIPDAU	Level-1-260C-UNLIM	-40 to 125	(CA35 ~ CA3R)	Samples
SN74LVC1G373DCKR	ACTIVE	SC70	DCK	6	3000	Green (RoHS & no Sb/Br)	CU NIPDAU	Level-1-260C-UNLIM	-40 to 125	(D35 ~ D3R)	Samples
SN74LVC1G373YZPR	ACTIVE	DSBGA	YZP	6	3000	Green (RoHS & no Sb/Br)	SNAGCU	Level-1-260C-UNLIM	-40 to 85	(D32 ~ D3N)	Samples

(1) The marketing status values are defined as follows:

ACTIVE: Product device recommended for new designs.

LIFEBUY: TI has announced that the device will be discontinued, and a lifetime-buy period is in effect.

NRND: Not recommended for new designs. Device is in production to support existing customers, but TI does not recommend using this part in a new design.

PREVIEW: Device has been announced but is not in production. Samples may or may not be available.

OBSELETE: TI has discontinued the production of the device.

(2) Eco Plan - The planned eco-friendly classification: Pb-Free (RoHS), Pb-Free (RoHS Exempt), or Green (RoHS & no Sb/Br) - please check <http://www.ti.com/productcontent> for the latest availability information and additional product content details.

TBD: The Pb-Free/Green conversion plan has not been defined.

Pb-Free (RoHS): TI's terms "Lead-Free" or "Pb-Free" mean semiconductor products that are compatible with the current RoHS requirements for all 6 substances, including the requirement that lead not exceed 0.1% by weight in homogeneous materials. Where designed to be soldered at high temperatures, TI Pb-Free products are suitable for use in specified lead-free processes.

Pb-Free (RoHS Exempt): This component has a RoHS exemption for either 1) lead-based flip-chip solder bumps used between the die and package, or 2) lead-based die adhesive used between the die and leadframe. The component is otherwise considered Pb-Free (RoHS compatible) as defined above.

Green (RoHS & no Sb/Br): TI defines "Green" to mean Pb-Free (RoHS compatible), and free of Bromine (Br) and Antimony (Sb) based flame retardants (Br or Sb do not exceed 0.1% by weight in homogeneous material)

(3) MSL, Peak Temp. - The Moisture Sensitivity Level rating according to the JEDEC industry standard classifications, and peak solder temperature.

(4) There may be additional marking, which relates to the logo, the lot trace code information, or the environmental category on the device.

(5) Multiple Device Markings will be inside parentheses. Only one Device Marking contained in parentheses and separated by a "~" will appear on a device. If a line is indented then it is a continuation of the previous line and the two combined represent the entire Device Marking for that device.

⁽⁶⁾ Lead/Ball Finish - Orderable Devices may have multiple material finish options. Finish options are separated by a vertical ruled line. Lead/Ball Finish values may wrap to two lines if the finish value exceeds the maximum column width.

Important Information and Disclaimer: The information provided on this page represents TI's knowledge and belief as of the date that it is provided. TI bases its knowledge and belief on information provided by third parties, and makes no representation or warranty as to the accuracy of such information. Efforts are underway to better integrate information from third parties. TI has taken and continues to take reasonable steps to provide representative and accurate information but may not have conducted destructive testing or chemical analysis on incoming materials and chemicals. TI and TI suppliers consider certain information to be proprietary, and thus CAS numbers and other limited information may not be available for release.

In no event shall TI's liability arising out of such information exceed the total purchase price of the TI part(s) at issue in this document sold by TI to Customer on an annual basis.

TAPE AND REEL INFORMATION

QUADRANT ASSIGNMENTS FOR PIN 1 ORIENTATION IN TAPE

*All dimensions are nominal

Device	Package Type	Package Drawing	Pins	SPQ	Reel Diameter (mm)	Reel Width W1 (mm)	A0 (mm)	B0 (mm)	K0 (mm)	P1 (mm)	W (mm)	Pin1 Quadrant
SN74LVC1G373DCKR	SC70	DCK	6	3000	178.0	9.2	2.4	2.4	1.22	4.0	8.0	Q3
SN74LVC1G373YZPR	DSBGA	YZP	6	3000	178.0	9.2	1.02	1.52	0.63	4.0	8.0	Q1

TAPE AND REEL BOX DIMENSIONS

*All dimensions are nominal

Device	Package Type	Package Drawing	Pins	SPQ	Length (mm)	Width (mm)	Height (mm)
SN74LVC1G373DCKR	SC70	DCK	6	3000	180.0	180.0	18.0
SN74LVC1G373YZPR	DSBGA	YZP	6	3000	220.0	220.0	35.0

MECHANICAL DATA

DBV (R-PDSO-G6)

PLASTIC SMALL-OUTLINE PACKAGE



- NOTES:
- A. All linear dimensions are in millimeters.
 - B. This drawing is subject to change without notice.
 - C. Body dimensions do not include mold flash or protrusion. Mold flash and protrusion shall not exceed 0.15 per side.
 - D. Leads 1,2,3 may be wider than leads 4,5,6 for package orientation.
- Falls within JEDEC MO-178 Variation AB, except minimum lead width.

DBV (R-PDSO-G6)

PLASTIC SMALL OUTLINE



- NOTES:
- A. All linear dimensions are in millimeters.
 - B. This drawing is subject to change without notice.
 - C. Customers should place a note on the circuit board fabrication drawing not to alter the center solder mask defined pad.
 - D. Publication IPC-7351 is recommended for alternate designs.
 - E. Laser cutting apertures with trapezoidal walls and also rounding corners will offer better paste release. Customers should contact their board assembly site for stencil design recommendations. Example stencil design based on a 50% volumetric metal load solder paste. Refer to IPC-7525 for other stencil recommendations.

DCK (R-PDSO-G6)

PLASTIC SMALL-OUTLINE PACKAGE



- NOTES:
- A. All linear dimensions are in millimeters.
 - B. This drawing is subject to change without notice.
 - C. Body dimensions do not include mold flash or protrusion. Mold flash and protrusion shall not exceed 0.15 per side.
 - D. Falls within JEDEC MO-203 variation AB.

DCK (R-PDSO-G6)

PLASTIC SMALL OUTLINE



- NOTES:
- All linear dimensions are in millimeters.
 - This drawing is subject to change without notice.
 - Customers should place a note on the circuit board fabrication drawing not to alter the center solder mask defined pad.
 - Publication IPC-7351 is recommended for alternate designs.
 - Laser cutting apertures with trapezoidal walls and also rounding corners will offer better paste release. Customers should contact their board assembly site for stencil design recommendations. Example stencil design based on a 50% volumetric metal load solder paste. Refer to IPC-7525 for other stencil recommendations.

YZP0006



PACKAGE OUTLINE

DSBGA - 0.5 mm max height

DIE SIZE BALL GRID ARRAY



D: Max = 1.418 mm, Min = 1.358 mm
 E: Max = 0.918 mm, Min = 0.858 mm

4219524/A 06/2014

NOTES:

NanoFree Is a trademark of Texas Instruments.

1. All linear dimensions are in millimeters. Any dimensions in parenthesis are for reference only. Dimensioning and tolerancing per ASME Y14.5M.
2. This drawing is subject to change without notice.
3. NanoFree™ package configuration.

EXAMPLE BOARD LAYOUT

YZP0006

DSBGA - 0.5 mm max height

DIE SIZE BALL GRID ARRAY



LAND PATTERN EXAMPLE
SCALE:40X



4219524/A 06/2014

NOTES: (continued)

- Final dimensions may vary due to manufacturing tolerance considerations and also routing constraints. For more information, see Texas Instruments literature number SBVA017 (www.ti.com/lit/sbva017).

EXAMPLE STENCIL DESIGN

YZP0006

DSBGA - 0.5 mm max height

DIE SIZE BALL GRID ARRAY



SOLDER PASTE EXAMPLE
BASED ON 0.1 mm THICK STENCIL
SCALE:40X

4219524/A 06/2014

NOTES: (continued)

5. Laser cutting apertures with trapezoidal walls and rounded corners may offer better paste release.

IMPORTANT NOTICE

Texas Instruments Incorporated and its subsidiaries (TI) reserve the right to make corrections, enhancements, improvements and other changes to its semiconductor products and services per JESD46, latest issue, and to discontinue any product or service per JESD48, latest issue. Buyers should obtain the latest relevant information before placing orders and should verify that such information is current and complete. All semiconductor products (also referred to herein as "components") are sold subject to TI's terms and conditions of sale supplied at the time of order acknowledgment.

TI warrants performance of its components to the specifications applicable at the time of sale, in accordance with the warranty in TI's terms and conditions of sale of semiconductor products. Testing and other quality control techniques are used to the extent TI deems necessary to support this warranty. Except where mandated by applicable law, testing of all parameters of each component is not necessarily performed.

TI assumes no liability for applications assistance or the design of Buyers' products. Buyers are responsible for their products and applications using TI components. To minimize the risks associated with Buyers' products and applications, Buyers should provide adequate design and operating safeguards.

TI does not warrant or represent that any license, either express or implied, is granted under any patent right, copyright, mask work right, or other intellectual property right relating to any combination, machine, or process in which TI components or services are used. Information published by TI regarding third-party products or services does not constitute a license to use such products or services or a warranty or endorsement thereof. Use of such information may require a license from a third party under the patents or other intellectual property of the third party, or a license from TI under the patents or other intellectual property of TI.

Reproduction of significant portions of TI information in TI data books or data sheets is permissible only if reproduction is without alteration and is accompanied by all associated warranties, conditions, limitations, and notices. TI is not responsible or liable for such altered documentation. Information of third parties may be subject to additional restrictions.

Resale of TI components or services with statements different from or beyond the parameters stated by TI for that component or service voids all express and any implied warranties for the associated TI component or service and is an unfair and deceptive business practice. TI is not responsible or liable for any such statements.

Buyer acknowledges and agrees that it is solely responsible for compliance with all legal, regulatory and safety-related requirements concerning its products, and any use of TI components in its applications, notwithstanding any applications-related information or support that may be provided by TI. Buyer represents and agrees that it has all the necessary expertise to create and implement safeguards which anticipate dangerous consequences of failures, monitor failures and their consequences, lessen the likelihood of failures that might cause harm and take appropriate remedial actions. Buyer will fully indemnify TI and its representatives against any damages arising out of the use of any TI components in safety-critical applications.

In some cases, TI components may be promoted specifically to facilitate safety-related applications. With such components, TI's goal is to help enable customers to design and create their own end-product solutions that meet applicable functional safety standards and requirements. Nonetheless, such components are subject to these terms.

No TI components are authorized for use in FDA Class III (or similar life-critical medical equipment) unless authorized officers of the parties have executed a special agreement specifically governing such use.

Only those TI components which TI has specifically designated as military grade or "enhanced plastic" are designed and intended for use in military/aerospace applications or environments. Buyer acknowledges and agrees that any military or aerospace use of TI components which have **not** been so designated is solely at the Buyer's risk, and that Buyer is solely responsible for compliance with all legal and regulatory requirements in connection with such use.

TI has specifically designated certain components as meeting ISO/TS16949 requirements, mainly for automotive use. In any case of use of non-designated products, TI will not be responsible for any failure to meet ISO/TS16949.

Products

Audio	www.ti.com/audio
Amplifiers	amplifier.ti.com
Data Converters	dataconverter.ti.com
DLP® Products	www.dlp.com
DSP	dsp.ti.com
Clocks and Timers	www.ti.com/clocks
Interface	interface.ti.com
Logic	logic.ti.com
Power Mgmt	power.ti.com
Microcontrollers	microcontroller.ti.com
RFID	www.ti-rfid.com
OMAP Applications Processors	www.ti.com/omap
Wireless Connectivity	www.ti.com/wirelessconnectivity

Applications

Automotive and Transportation	www.ti.com/automotive
Communications and Telecom	www.ti.com/communications
Computers and Peripherals	www.ti.com/computers
Consumer Electronics	www.ti.com/consumer-apps
Energy and Lighting	www.ti.com/energy
Industrial	www.ti.com/industrial
Medical	www.ti.com/medical
Security	www.ti.com/security
Space, Avionics and Defense	www.ti.com/space-avionics-defense
Video and Imaging	www.ti.com/video

TI E2E Community

e2e.ti.com